

MEGALINE FLF 8 FRONT-END LOADER



**QUIET. POWERFUL.
SUSTAINABLE.**

The future is electric.
Now also as
an **e-version!**

SEPARATING COLLECTION AND TRANSPORT.

First class in performance and manoeuvrability: The THS MegaLINE FLF 8 front-end loader is a single-person operation, economical answer to the requirements of commercial and industrial waste collections.

MADE-TO-MEASURE COST-EFFECTIVE COLLECTIONS

By use of the MegaLINE FLF 8 front-end loader the process chain for collection and transport is efficiently closed and the need for skip loaders removed.

Everything from a single source:
We support you with individual, integrated and economical solutions - from planning, analysis and design to implementation, delivery and service.



Spare parts supply and service: Original spare parts are usually available within 24 hours subject to delivery wherever you are in the world.

TERBERG HS MODULAR SYSTEM

According to your requirements, we configure a vehicle that is individually tailored to your needs by combining different variants and taking the following factors into account:

Highest application flexibility on the market: Whether with a fixed container body or as an interchangeable unit.

Powerful removal: The MegaLINE FLF 8 proves its clearing qualities through different body lengths with different loading volume variants from 30 to 43 m³.

Manoeuvrable: Extreme manoeuvrability thanks to wheelbases from 3,900 mm or, in the 4-axle model (triple-axle) from 4,800 mm.

Container receptacle capacities: Flexibly selectable, specially tailored to your requirements. Maximum convenience: Smart and safe operating concept.

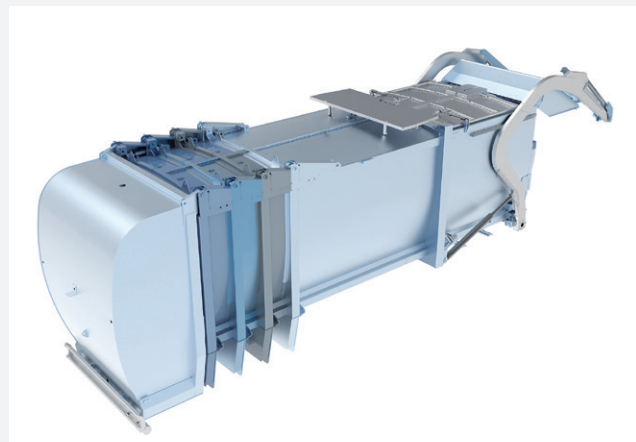

SMART EQUIPMENT - CUSTOMISED OPTIONS



COMBINATED FORK

- The combination fork is the ideal solution for emptying FEL containers and 1,100 l flat lid MGBs
- In combination with comb also suitable for 1,100 l sliding lid

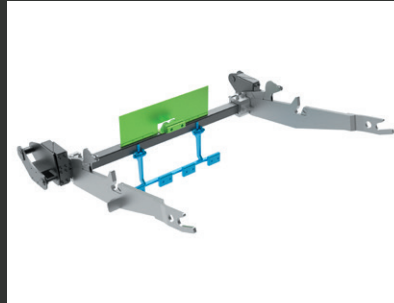

COMBINATED U5 FORK

- Ideal solution for emptying FEL containers, 1,100 l flat lid MGBs and U2,5/U5 dischargeable container
- In combination with comb also suitable for 1,100 l sliding lid



SCREWABLE ADAPTER

- Ideally suited for accommodating ASK skips with lids up to 10 m³
- In combination with a standard front loading fork (and only possible with fork rest on the body)



HIGH-QUALITY FEATURES

- Protected cable harnesses prevent damage
- Optimised control of the pressure plate, increased performance and less contamination



SHORTENED REAR LID

- Creates short overhang for optimum manoeuvrability
- Ideal for heavy fractions



ADDITIONAL WIND DEFLECTOR

- Prevents material blowing away
- Different lid drive options available



MEGALINE FLS 7 WITH CONTAINER CHANGING SYSTEM

- To separate collection and transport
- According to DIN 30722
- Suitable for ACTS



CRANELINE FLF 8

- Special component for emptying depositing containers or underground systems
- Tailor-made implementation of customer requirements
- Insertion slot with sliding plane



UNILINE FLF

- Specifically developed to meet the requirements of animal carcass disposal
- Container made of V2A stainless steel
- Driver does not need to leave the vehicle

TECHNICAL CHARACTERISTICS OF THS MEGALINE FLF 8

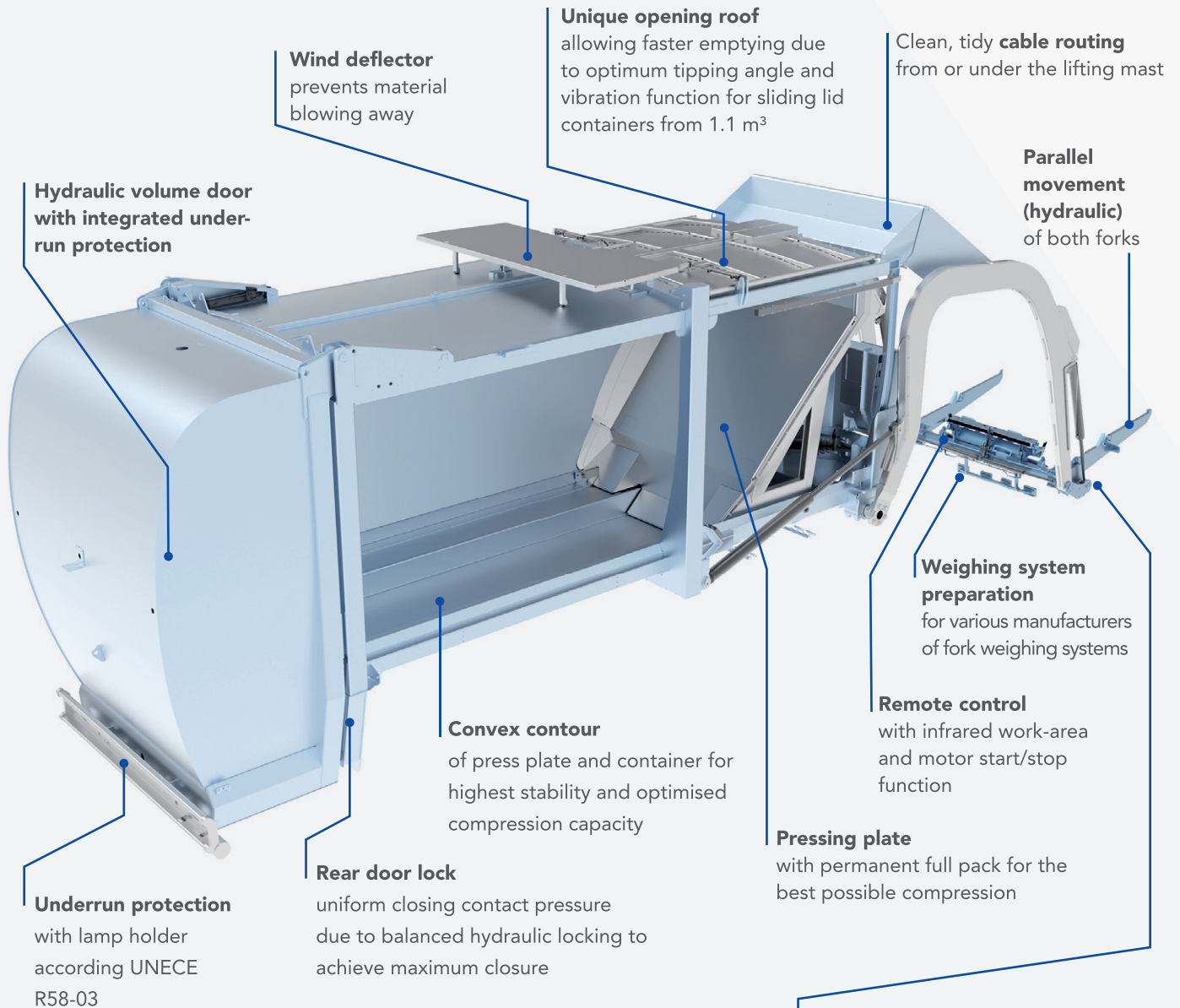

At Terberg HS you not only get state-of-the-art waste collection vehicles - you also get system solutions from a single source. And our front loaders are always tailored exactly to your requirements – with equipment that is optimised for your application with the very best of available technology.

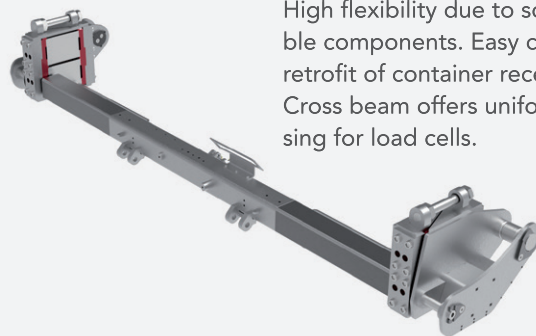

6 GOOD REASONS FOR THE THS MEGALINE FLF 8

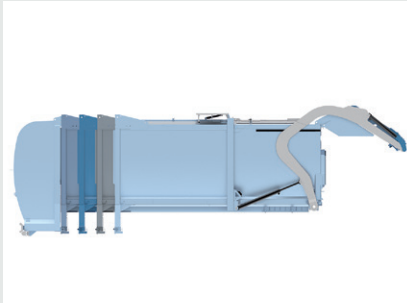

1. FLEXIBILITY

- Volume options with different body lengths and rear door options: 30 m³ to 43 m³
- Container receptacle capacities from 120 l to 10 m³



2. PERFORMANCE

- Single-person operation
- Payload for 3-axle up to 9 t and 4-axle up to 13 t
- Maximum volume on shortest wheelbases



3. WORK SPEED

- Superb manoeuvrability due to wheelbases from 3,900 mm
- Compaction on the move
- Short cycle times
- Fast discharge



4. SAFETY

- Unrestricted field of vision independent of the lifting system stow away (different versions)
- Remote control with infrared work-area protection
- Safety barrier on the roof of the superstructure
- Safety handle at the access point under the maintenance door



5. COMFORT

- Comfortable MD5 control system with 5-inch touchscreen and intuitive 6-button keypad
- Sensitive joystick
- Ergonomically shaped armrest with integrated USB port and practical holders
- Quiet operation



6. AVAILABILITY

- Requires minimal maintenance
- Remote maintenance via Bluetooth
- Fair service contracts minimise downtime
- Original spare parts available within 24 hours
- Terberg Connect - software for your fleet management