

OLYMPUS MINI

HIGH COMPACTION IN NARROW STREETS

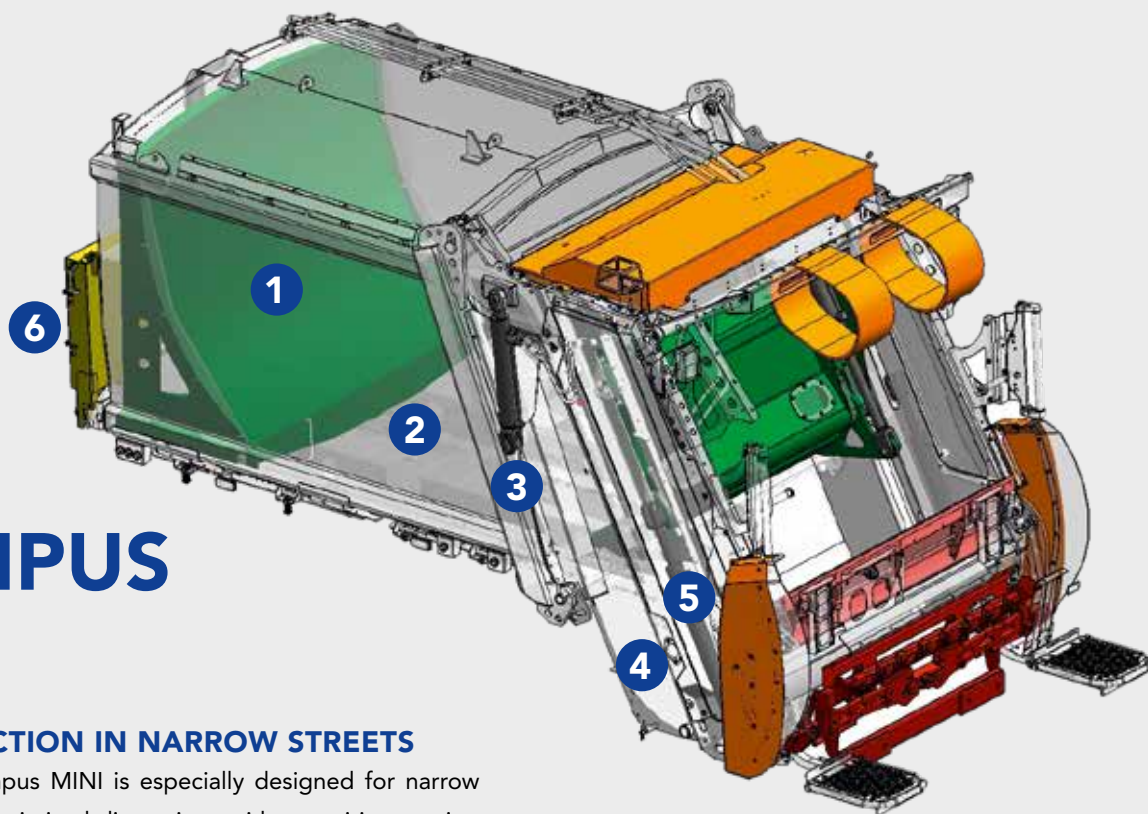

Olympus MINI is a rear loading refuse compaction vehicle for the collection of domestic and organic waste as well as recycling materials in pedestrian, city centre and rural areas with narrow streets and restricted access that requires a high level of manoeuvrability. Compact, with an elegant design and proven technology, offers the best quality and reliability for the most demanding waste collection experts.



OLYMPUS MINI

HIGH COMPACTION IN NARROW STREETS

Our range of Olympus MINI is especially designed for narrow streets due to its optimised dimensions with capacities ranging from 6 to 8m³.



1 Ejector plate perfectly fitted to the body.

2 Sloped floor with side ejector guides.

3 Complete tailgate seal.

4 Minimum overhang.

5 External compaction cylinders.

6 Electrical control panel in an easily accessible place.

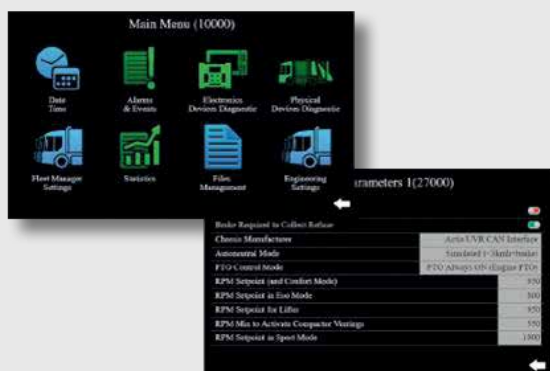

Configurable HMI display:

- All our Olympus waste collection models are equipped with a multifunction control monitor installed in the vehicle cab which facilitates the fully intuitive configuration of the different equipment functions:
- Tailgate, packer plate, ejector plate, bin-lifter movements and waste type are configured from the cab.
 - Integration of different weighing systems shown in the same display with real-time information.
 - Auto diagnostic system integrated in the display with information regarding equipment operating status. Includes alarms in the event of malfunction.
 - Alarm log. The systems stores up to 2000 alarms in order to facilitate the generation of diagnostic reports.
 - Configurable in any language.
 - Load control from cabin if available with specified weighing system.
 - Possibility to configure as a 7" rear camera screen.

ADVANTAGES OF THE OLYMPUS MINI REFUSE COLLECTOR VEHICLE

Robust design with an overall lightweight construction: high quality and strength materials that at the same time warranties the maximum payload.

Wide range of capacities: 6,7 and 8m³. More capacity with the same manoeuvrability.

2m width.

For use with our **own bin-lifter** technology created to be adapted to this kind of range and the OmniTRADE lifter.

One-man operated.

It can be mounted to a **small chassis** (7.5-11t).

Load on a **12v or 24 v vehicle chassis**.

Payload maximization: according to the chassis and collection equipments selected.

High compaction ratios: up to 6:1.

Cycle time 15 seconds.

Only 2 greasing points in body and tailgate.

Heavy duty packing cylinders mounted outside the hopper, clear of the loading area.

Vane pumps with low-noise level.

Reduced overhang for improved weigh distribution and manoeuvrability.

Hopper clean cycle in unloading mode electrically controlled from a control panel at ground level.

Electrical control panel accessible from ground level.

Manufactured in high resistance rolled steel giving greater resistance to abrasion and corrosion.

Wiring system with "Heavy Duty" connectors (Euro 6 level).

LED lights.

It is characterized by **low costs** and **easy maintenance**.

It works harder, lasts longer.

Optionals: wide range of accessories and options.



MULTI-PURPOSE MINI BIN-LIFTER

Our multi purpose binlift, suitable for bins and containers is specially designed for domestic waste collection with manual operation by push button controls. Lifting is carried by comb and/or optional DIN arms.



NOTEWORTHY OPTIONS FOR OLYMPUS MINI EQUIPMENT

- Hydraulic unloading of underground containers.
- Lifter with lid openers and DIN arms.
- Available without lifter, as open back.
- Continuous cycle option, with optical barriers.
- End of compaction mechanism during travel.
- Foldable rave rail.
- Footboards.
- Shovel and brush.

In addition to the previously indicated options, the Olympus MINI range is characterised by the versatility with which it can incorporate innovative solutions. For more information, please contact our sales department.

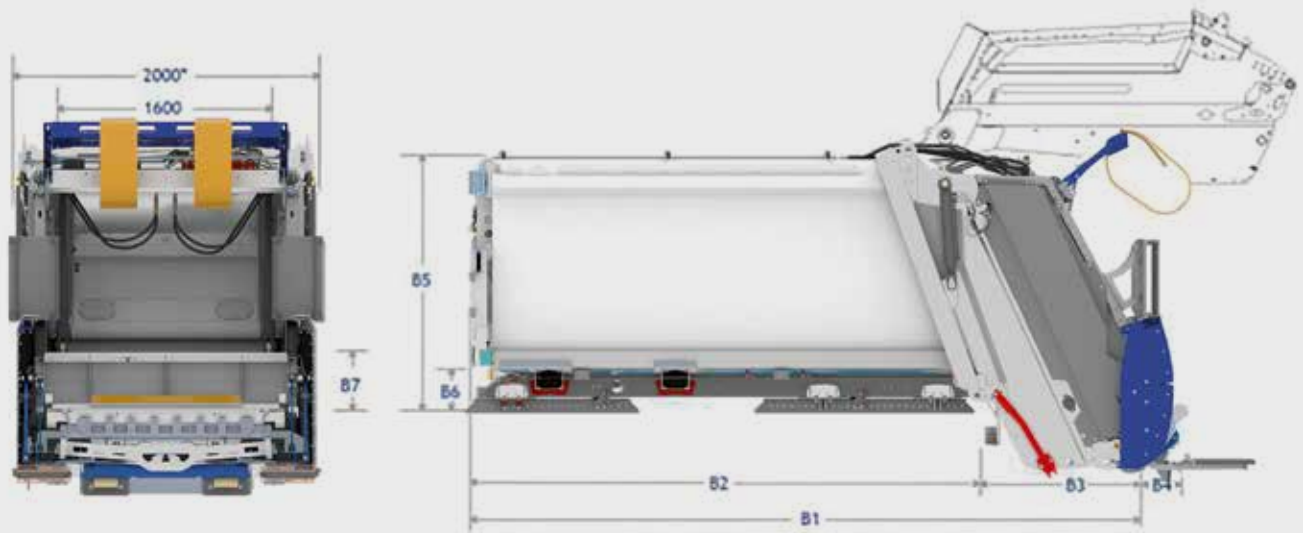



	Capacity (m³)	Wheel bases (mm)	A Maximum external width (mm)	B Length (mm)	C Height (*) (mm)	Hopper volume (m³)	D Hopper internal width (mm)	GVW	 (up to 390 L) EN840-1	 (up to 1100 L) EN840-2	 (up to 1100 L) EN840-3
OLYMPUS MINI											
MINI 6	6	2,700-2,900		4,030				7.5-8 T	•	•	•
MINI 7	7	3,100-3,350	2,000 / 2,100 (*) With holders and footboards)	4,430	2,000	1	1,600	8.5-9 T	•	•	•
MINI 8	8	3,500-3,800		4,830				10-12 T	•	•	•

(*) Height from the chassis platform.

Certifications

- Compliance with European standard EN1501-1 and EN1501-5.
- Compliance with Directive 2006/42/EC on machinery safety.
- Compliance with European standard 2000/14/EC on noise emission.
- Certificate of hydraulic fluid cleanliness in accordance with ISO 4406.



TERBERG ENVIRONMENTAL

Postbus 202, 3400AE. IJsselstein, The Netherlands

T +31 (0) 30 68 68 700, E sales@terbergenvironmental.com, I www.terbergenvironmental.com

We reserve the right to carry out technical modifications. Modification of specifications may be carried out without prior notice. Illustrations may not necessarily depict current equipment versions.