

Olympus Twin Pack Service Manual

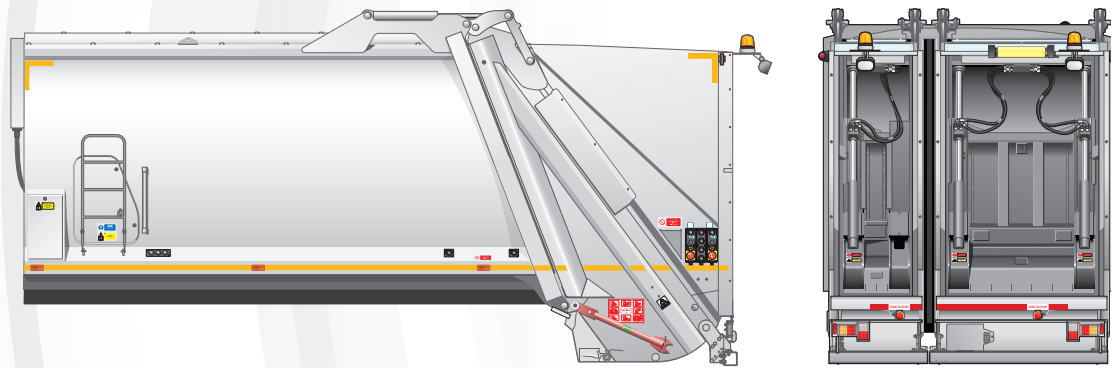

www.dennis-eagle.co.uk

DENNIS EAGLE
RosRoca



Olympus Twin Pack Service Manual

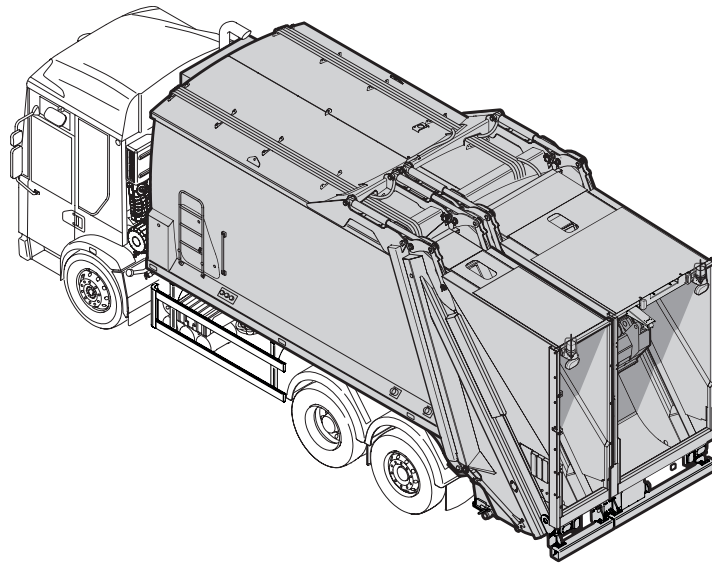

Dennis Eagle Olympus Twin Pack Refuse Collection Vehicle

This Service Manual provides all the relevant service information and data necessary to carry out designated scheduled maintenance inspections and procedures on systems and components fitted to the Dennis Eagle Olympus Twin Pack Refuse Collection Vehicle.

This Service Manual is primarily designed to assist skilled technicians in the efficient servicing and repair of the systems and components described in the manual, but can also be used as a reference workbook for training purposes.

The information in this Service Manual must be used in conjunction with the Service Manuals for the chassis-cab and any ancillary equipment such as waste container lifting devices fitted to the refuse collection vehicle.



Caution:

IMPORTANT: It is assumed that technicians carrying out service procedures described in this Service Manual appreciate, understand and carry out all workshop safety and repair procedures generally accepted by the motor vehicle repair industry.

It is most important, however, that all technicians read and understand and observe all the instructions stated in Chapter 2 'Health and safety' of this Manual whenever undertaking any procedures described in this Manual.



Dennis Eagle Ltd. (the Company) reserves the right to change the specification, design, material, procedures and dimensions of the vehicles described within this publication without prior notice at any time in the future, in accordance with the Company's policy of continuous product improvement.

Dennis Eagle Ltd. has made every reasonable effort to ensure the accuracy of the Company publications, but nothing shown, described or referred to in the publications should be regarded as an infallible guide to the procedures, materials, specification, design or availability of any particular vehicle, nor does this publication constitute an offer for sale of any particular vehicle. No liability can be accepted by the company for any mechanical or electrical malfunction, damage, loss injury or death caused by the use of incorrect or misrepresented information, omissions or errors that may have arisen during the preparation of this publication.

© 2015 Dennis Eagle Ltd.

ALL RIGHTS RESERVED.

No part of this publication may be reproduced, stored in a retrieval system or transmitted in any form without the prior permission of the Company.

Original instructions.

Compiled and Published by:

Technical Support Group

Dennis Eagle Ltd.

Heathcote Way

Heathcote Industrial Estate

Warwick

CV34 6TE

United Kingdom

Telephone: +44 (0)1926 316000

Facsimile: +44 (0)1926 316550

www.dennis-eagle.com

Description

The Olympus Twin Pack refuse collection bodywork is a rear loaded, fixed refuse collection bodywork manufactured to EN 1501-1.

Intended use

The Olympus Twin Pack refuse collection bodywork shall be mounted on chassis-cabs specified for refuse collection application and shall be used to collect and transport domestic and industrial waste and recyclable materials.

The Olympus Twin Pack refuse collection bodywork is not designed for:

- Operation in severe conditions, e.g. extreme environmental conditions such as:
 - Below - 25 °C and above + 40 °C temperatures.
 - Operation in a tropical environment.
 - Operation in wind velocity in excess of 75 km/h.
- Operation in a contaminating environment.
- Operation in a corrosive environment.
- Operation in potentially explosive atmospheres.
- Handling of loads the nature of which could lead to dangerous situations (e.g. hot wastes, acids and bases, radioactive materials, contaminated waste, especially fragile loads, explosives).
- Operation on ships.

Manufacturer's name and address

Dennis Eagle Ltd.

Heathcote Way

Heathcote Industrial Estate

Warwick

CV34 6TE

United Kingdom.

Edition	Publication reference	Publication date	Comments
This edition	OT1D-SM-GB03D	December 2015	New edition for introduction of narrow variants.
Previous editions	OT1D-SM-GB02D OT1D-SM-GB01D	June 2014 January 2013	Third edition - Elite 6 chassis-cab. Second edition - new corporate identity.



Olympus Twin Pack Service Manual

CONTENTS		PAGE
1	Introduction.....	1-1
2	Health and safety.....	2-1
3	Daily checks.....	3-1
4	Hydraulic system oil level.....	4-1
5	Cleaning	5-1
6	Scheduled maintenance	6-1
7	Operational maintenance	7-1
8	General specification data	8-1
9	Supplementary information	9-1
I	Index	I-1



This page intentionally left blank



Olympus Twin Pack Service Manual

CONTENTS		PAGE
1	Introduction.....	1-3
1.1	Safety precautions.....	1-3
1.2	Immobilising the vehicle prior to service procedures.....	1-3



This page intentionally left blank



1 Introduction

This manual identifies all the recommended preventative maintenance service procedures and inspections to be carried out on Olympus Twin Pack refuse collection bodywork.

1.1 Safety precautions



WARNING:
IT IS THE RESPONSIBILITY OF THE TECHNICIAN TO COMPLY WITH ALL THE RELEVANT SAFETY PRECAUTIONS AND PROCEDURES LISTED IN CHAPTER 2 'HEALTH AND SAFETY' OF THIS MANUAL WHEN CARRYING OUT THE PROCEDURES DESCRIBED IN THIS MANUAL.

1.2 Immobilising the vehicle prior to service procedures

Before commencing any service procedure, the refuse collection vehicle must be immobilised as follows:

1. Stand the vehicle on clean, level and stable ground.
2. Engage the parking brakes.
3. Select Neutral 'N'.
4. Stop the engine.
5. Chock the wheels.
6. Check that the tailgates are in the normal lowered position, locked to the body.
7. Turn the 'Body main' switch to off position. Remove and retain the key.
8. Switch ignition off. Remove and retain the key.
9. Secure a sign reading 'DO NOT START OR OPERATE VEHICLE' to the steering wheel.
10. Lock all cab doors. Remove and retain the keys.
11. If necessary isolate or disconnect the battery. (Refer to chassis-cab manufacturer's service information for procedures).



This page intentionally left blank



Olympus Twin Pack Service Manual

CONTENTS	PAGE
2 Health and safety.....	2-3
2.1 Introduction.....	2-3
2.2 Safety symbol, warnings, cautions and notes.....	2-3
2.3 Trained personnel.....	2-3
2.4 Use of these instructions.....	2-3
2.5 Precautions and protection for personnel.....	2-4
2.5.1 Personal hygiene.....	2-4
2.5.2 Protective clothing.....	2-4
2.6 Working at high level.....	2-5
2.7 First aid and emergency treatment.....	2-6
2.7.1 Workshop first aid equipment.....	2-6
2.7.2 Cuts and wounds.....	2-6
2.7.3 Carbon monoxide poisoning.....	2-6
2.7.4 Burns.....	2-6
2.7.5 Contact with and/or ingestion of fluids.....	2-6
2.8 Workshop precautions, procedures and practices.....	2-7
2.8.1 Material safety data sheets.....	2-7
2.8.2 Responsible technician, the Key Holder.....	2-7
2.8.3 Immobilising the vehicle.....	2-8
2.8.4 General workshop precautions.....	2-8
2.8.5 Workplace cleanliness.....	2-8
2.8.6 Moving or rotating parts.....	2-8
2.8.7 Hot components.....	2-9
2.8.8 'Live' work.....	2-9
2.8.9 Fasteners.....	2-9
2.8.10 Protecting vehicle components during grinding, drilling and welding.....	2-9
2.8.11 Welding on or near the vehicle.....	2-9
2.8.12 Manual handling and movement of loads.....	2-10
2.8.13 Access and lifting equipment.....	2-10
2.8.14 Cleaning of equipment.....	2-10
2.8.15 Environmental protection precautions.....	2-10
2.8.16 Fuel, oil, lubricants, degreasants and filters.....	2-10
2.8.17 Solvents.....	2-10
2.8.18 Contact with plastic material residues after fires.....	2-11
2.9 Cleaning a bodywork.....	2-11
2.9.1 Pressure washing.....	2-11



HEALTH AND SAFETY

2

2.10	Vehicle electrical systems	2-12
2.10.1	General electrical precautions.....	2-12
2.10.2	Disconnection and reconnection of electrical components.....	2-12
2.11	Welding on or near the vehicle.....	2-12
2.12	Hydraulic and pneumatic systems.....	2-13
2.13	Returning the vehicle to service.....	2-13



2 Health and safety

2.1 Introduction

This chapter states the precautions to be observed by personnel carrying out maintenance operations on an Olympus Twin Pack refuse collection bodywork.

Precautions to be observed by personnel operating an Olympus Twin Pack refuse collection bodywork are contained in the equivalent chapter of the Olympus Twin Pack Operator's Handbook.

It is everyone's responsibility to make sure that they and their colleagues work safely. The intention of these guidelines is to draw to the attention of Service Technicians the importance of safety issues and to highlight known hazards. Read this chapter very carefully and use the procedures as a guide to safe working practice at all times. If necessary, discuss any points that are not clear with your Safety Officer or Manager.

The guidelines contained in this Manual are not definitive and do not override nor replace local rules and instructions. There may be additional ways to make sure that operative and maintenance organisations work safely and you must also follow any local rules and safe working practices that may apply.

The information in this chapter should be used in conjunction with the appropriate chapters of the workshop manuals, operator's handbooks or other service information applicable to the vehicle chassis-cab and any ancillary equipment such as waste container lifting devices, etc. fitted to the vehicle.

Special attention should be paid to safety procedures and precautions which must be observed with electronic systems, high pressure fuel systems, urea injection systems, high temperature catalyst exhaust systems and air conditioning refrigeration systems fitted to modern commercial vehicle chassis-cab.

2.2 Safety symbol, warnings, cautions and notes

The following Safety Symbol is used throughout this Manual to indicate information that is essential to Health and Safety. The symbol applies to ALL information contained in this chapter.



All Safety Information MUST be strictly adhered to.



WARNING:
A WARNING IS PRINTED IN THIS STYLE. IT REFERS TO ANY PROCEDURE WHICH MUST BE FOLLOWED PRECISELY TO AVOID POSSIBILITY OF PERSONAL INJURY OR DEATH.



Caution:
A Caution is printed in this style. It refers to any procedure which must be followed to avoid damage to components or cause them to malfunction.

Note:

A Note is printed in this style. It refers to essential information about any operation or event that is not a **WARNING** or **Caution**.

2.3 Trained personnel

The vehicle may be dangerous in the wrong hands, and only suitably trained and authorised persons using approved safety equipment where relevant, should operate, service and repair this vehicle.

Maintenance personnel must have completed an approved training course including the following:

- Safety precautions to be observed when operating and carrying out maintenance and repairs to the refuse collection vehicle.
- Working safely at height.
- Checking of the safety devices.
- Identification of components requiring maintenance for keeping the refuse collection vehicle safe and the intervals at which servicing is required.
- How to use the lifting points of heavy components or sub-assemblies that have to be lifted in one piece.

2.4 Use of these instructions

These instructions are only intended for use by trained and authorised personnel with the vehicle(s) for which this Manual is applicable. They should not be used by any other persons, on any other vehicle or for any other purpose.



HEALTH AND SAFETY

2

2.5 Precautions and protection for personnel

2.5.1 Personal hygiene

Personal hygiene is important at all times, particularly for those working in the waste disposal environment where rats can breed and spread diseases such as **LEPTOSPIROSIS**.

Leptospirosis, or Weil's disease, is a form of jaundice with early stages similar to influenza.

The infection sometimes enters the body through breaks in the skin, so thorough first aid treatment of all wounds is important.

Leptospirosis is carried in the urine of rats. If you have the slightest suspicion that you are working in a contaminated environment follow these rules rigidly:

1. Wear protective clothing at all times.
2. Do not allow the inside of protective clothing to become soiled.
3. After removing protective clothing wash it thoroughly and allow to dry.
4. Wash hands and forearms thoroughly after working and especially before eating and drinking.
5. Wash every scratch, graze or cut of the skin, treat it with antiseptic, and cover it with a sterile dressing, e.g. plaster. This applies to ALL wounds; not just those suffered at work.
6. If the First-Aid kit requires replenishing, report it to your supervisor.
7. With any injury that is more than a scratch or slight cut, consult your doctor and mention the type of work you do.
8. Do not rub your mouth, nose or eyes when working.
9. At all visits to your doctor, mention the type of work you do and the environment you work under.
10. Apply barrier creams before each work period.

Note: Preparations containing lanolin replace the natural skin oils which can be removed when washing.

11. Do not wash skin with fuels, thinners or solvents.
12. Obtain medical advice if skin disorders develop.

2.5.2 Protective clothing

1. Use and take care of all personal protective clothing and equipment supplied by your employer for your safety.
2. While operating or carrying out maintenance on a refuse collection vehicle, wear protective clothing complying with health and safety legislation and standards applicable to the country in which the vehicle is being used, including:
 - A boiler suit, or a two piece protective overall, not too loosely fitting and of a distinctive colour.
 - Protective boots or shoes with steel toe caps and in-soles.
 - A hard protective hat.
 - Protective gloves.
 - Protective spectacles.
 - Goggles and particle mask if working in dusty conditions.
 - Suitable eye protection to protect eyes from welding flash or sparks from grinding.
 - Reflective armbands or jacket when working on the road.
3. Wear impervious gloves where there is a risk of contact with hydraulic system oil.
4. Wear eye protection (chemical goggles or face shields) where there is a risk of eye contact.
5. Avoid contaminating clothes and protective equipment with oil:
6. Do not put oily rags in pockets.
7. Clean overalls regularly.
8. Discard unwashable or oil impregnated clothing.
9. Do not wear loose fitting clothing whilst operating or carrying out maintenance on the vehicle.
10. Always remove all personal jewellery, e.g. rings, watches, chains etc., before commencing operation or work on the vehicle.
11. Tie long hair back from the face.



2.6 Working at high level



WARNINGS:
FAILURE TO OBSERVE THE FOLLOWING PRECAUTIONS MAY RESULT IN INJURY OR DEATH.

DO NOT UNDER ANY CIRCUMSTANCE WALK ON OR LOAD THE PLASTIC TAILGATE ROOF COVERS (SEE FIG. 2-1, 1). THESE ARE NOT LOAD-BEARING STRUCTURES.

SAFETY HARNESS ATTACHMENT LUGS (SHAL) SHOULD NOT UNDER ANY CIRCUMSTANCES BE USED AS LIFTING POINTS TO RAISE THE BODYWORK.

High level components and equipment mounted on the roof of the body and tailgates are generally located in positions accessible from the side or rear of the vehicle.

Where possible, any maintenance (inspection, replacement, repairs) of high level components and equipment mounted on the body or tailgate should be carried out using suitable access platforms to either side or rear of the vehicle.

Access platforms should be used in compliance with all prevailing Health and Safety Regulations, Workshop Regulations and Workshop Codes of Practice.

Where components cannot be accessed from the side or rear of the vehicle and it becomes necessary to work on top of the body roof or tailgate, always wear an approved safety harness connected to a Safety Harness Attachment Lug (see Fig. 2-1, 2) in accordance with all prevailing safe systems of work, Health and Safety Regulations, Workshop Regulations and Workshop Codes of Practice.

Safety Harness Attachment Lugs (SHAL) are primarily designed for the use of Dennis Eagle manufacturing, production and service personnel when working at height on vehicle roofs in line with risk assessments and safe systems of work conducted at Dennis Eagle.

Customers may use the Safety Harness Attachment Lugs only if they have conducted necessary risk assessments and prescribed subsequent safe systems of work based on their own activities.

If in doubt, contact your local Health and Safety Officer.

If access to components under the covers is required, remove them first as described in the appropriate sections of the Olympus Twin Pack Workshop Manual.

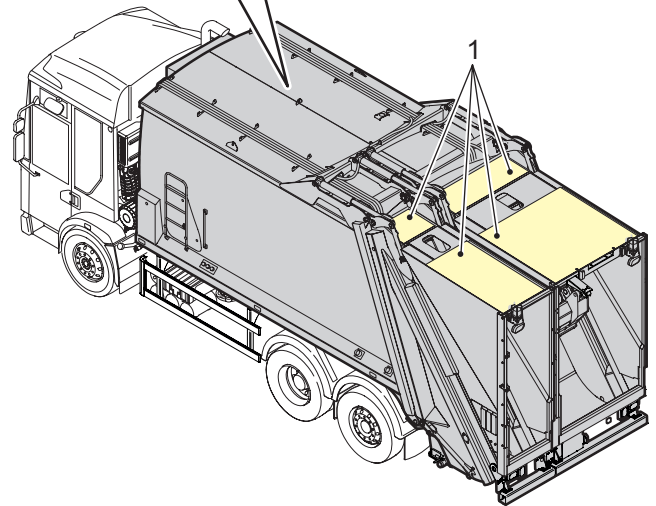
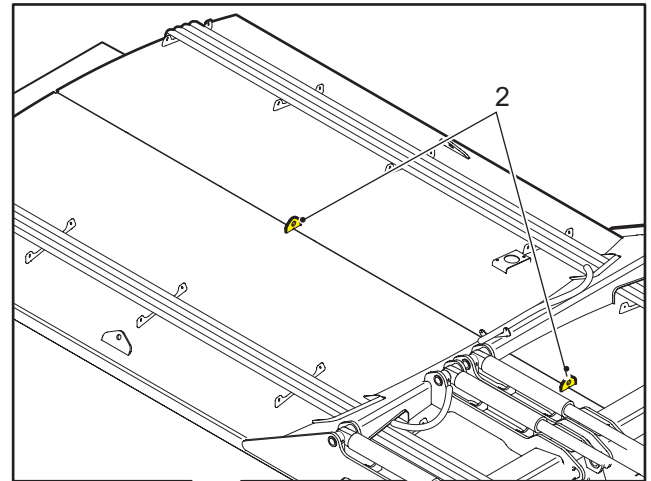

2429-OT1-D-GB-G3

Fig. 2-1 Tailgate Safety Harness Attachment Lug (SHAL)

1. Tailgate roof covers.
2. Safety Harness Attachment Lug (SHAL).



HEALTH AND SAFETY

2

2.7 First aid and emergency treatment

2.7.1 Workshop first aid equipment

1. The workshop must be equipped with First Aid equipment complying with local legislation.
2. Familiarise yourself with the equipment, procedures and practices.
3. If the first-aid kit requires replenishing report it to your supervisor.

2.7.2 Cuts and wounds

1. Treat open cuts and wounds immediately.
2. Wash every scratch, graze or cut of the skin, treat it with antiseptic, and cover it with a sterile dressing, e.g. plaster. This applies to ALL wounds; not just those suffered at work.

2.7.3 Carbon monoxide poisoning

If Carbon Monoxide poisoning is suspected:

1. Move the patient into fresh air immediately, keeping the patient at rest and warm.
2. Administer artificial respiration if the patient has stopped breathing.
3. Summon an ambulance and send the patient to hospital. If an ambulance is not available, make sure the patient is accompanied by a proficient First aid person.

2.7.4 Burns

In the event of a skin burn, immediately administer the following emergency treatment:

1. Run cold, clean water over the affected area.
2. Cover the burned area, including any clothing, with a dry, clean, sterile dressing.
3. Consult a medical centre or doctor as soon as possible.

Do not:

- Remove any clothing over the burn.
- Burst any blisters.
- Apply any cream or oily preparation to the burned area.

2.7.5 Contact with and/or ingestion of fluids

For First aid instructions covering ingestion, inhalation, skin or eye contact with fluids used in systems and components fitted to vehicles for which this Manual is applicable, consult the appropriate Safety Data Sheet contained in this chapter.



2.8 Workshop precautions, procedures and practices

2.8.1 Material safety data sheets

The European Commission's Chemical Agents Directive (CAD) (98/24/EC) establishes minimum health and safety conditions for the protection of the health and safety of workers from the risks related to chemical agents at work.

This Directive is implemented In Great Britain by the Control of Substances Hazardous to Health Regulations 2002 (COSHH), which requires employers to control exposure to hazardous substances to prevent ill health.

Further information about COSHH, refer to: <http://www.hse.gov.uk/coshh/>

Similar legislation may exist in other countries.

In compliance with this legislation, manufacturer's of chemical agents, including diesel fuel, lubricating oils, anti-freeze, screen-wash and etc., are required to produce Safety Data Sheets detailing specific information about the hazards of the product.

Hazardous substances include:

- Substances used directly in work activities (e.g. adhesives, paints, cleaning agents).
- Substances generated during work activities (e.g. fumes from soldering and welding).
- Naturally occurring substances (e.g. grain dust).
- Biological agents such as bacteria and other microorganisms.

COSHH requires employers to:

- Assess the risks to health from hazardous substances used in or created by workplace activities.
- Not carry out work which could expose employees to hazardous substances without first considering the risks and the necessary precautions, and what else is required to comply with COSHH.
- Prevent or control employees' exposure to hazardous substances.
- Ensure that control measures are used and maintained properly and that safety procedures are followed.
- Monitor the exposure of employees to hazardous substances, where necessary.
- Carry out appropriate health surveillance where necessary or COSHH sets specific requirements.
- Prepare plans and procedures to deal with accidents, incidents and emergencies involving hazardous substances, where necessary.
- Provide employees with suitable and sufficient information, instruction and training.

- Manufacturers of Substances Hazardous to Health are required by law to provide Safety Data Sheets for each product.

It is the responsibility of all personnel who may come into contact with such substances to familiarise themselves with the hazard and to take the necessary steps as advised by the data sheet(s).

Customers are recommended to store copies of Safety Data Sheets and other safety information pertinent to systems and components fitted to vehicles for which this Manual is applicable at the end of this chapter. There may be additional ways to make sure that operative and maintenance organisations work safely and you must also follow any local rules and safe working practices that may apply.

2.8.2 Responsible technician, the Key Holder

1. One person, the Key Holder, must be responsible for the safety of all personnel involved when a vehicle is undergoing any form of maintenance work. Normally the Key Holder will be the person who is working on the vehicle.
2. The Key Holder is responsible for immobilising the vehicle.
3. Any other person who needs access to the vehicle for whatever reason must inform the Key Holder of their intentions.
4. On completion of work all personnel must inform the key holder that they are leaving the vehicle.
5. If the Key Holder leaves the vehicle for any reason, he must nominate a new Key Holder and make sure that all affected personnel know who the new Key Holder is.
6. The Key Holder must make sure that when the engine is run, all personnel are clear of the bodywork until the engine is stopped and the ignition key is removed with the cab door locked.



2.8.3 Immobilising the vehicle

To immobilise the vehicle the Key Holder must:

1. Turn the 'Body main' key operated switch to off and remove the key and any spare keys (see Refuse Collection Vehicle Operator's Handbook).
2. Turn the ignition switch to off and remove the key and any spare keys.

Note: The ignition keys on Dennis Eagle Elite 6 vehicles are not specific to each vehicle.

3. Secure a sign reading 'DO NOT START OR OPERATE VEHICLE' to the steering wheel.
4. Lock all the cab doors and remove the key and any spare keys.
5. Retain all the keys while work is in progress.
6. If required, turn the vehicle's battery isolation switch, if fitted, to off or disconnect the vehicle's battery.

2.8.4 General workshop precautions

1. Chock the vehicle wheels at all times when maintenance work is in progress (Refer to chassis-cab manufacturer's Workshop Manual for information and instructions).
2. Personnel must not enter the body or tailgate hopper unless the engine is stopped, the cab door is locked and the Key Holder has been advised of work in progress.
3. If it is necessary to work on the roof of the vehicle, an approved safety harness MUST be worn and attached to a vehicle Safety Harness Attachment Lug (SHAL).
4. Use exhaust gas extraction hoses and equipment when running engines within an enclosed working area.
5. Where practicable, degrease components prior to handling.
6. Do not work under the vehicle when supported only by a jack; always use safety stands.
7. Only use the correct tools for the task, do not improvise.
8. Follow all precautions relating to the use of power tools.
9. Do not stare directly into the beams of high brightness LEDs, such as LED lamps and warning lamps; doing so may cause permanent damage to your eyes.

2.8.5 Workplace cleanliness

A clean and tidy workplace is a safe workplace.

1. Put rubbish in bins and do not allow it to accumulate.
2. Mop up oil or coolant spillages immediately using an approved method.
3. Do not leave tools or equipment lying around.
4. Do not allow hoses or cables to cross the workplace.

2.8.6 Moving or rotating parts

There are risks of serious injury due to entanglement or collision with rotating parts such as fans, engine components or propeller shafts.

All personnel must be aware of the risks and take precautions to distance themselves from moving or rotating parts at all times.

All guards are to be fastened in position when the vehicle is operational.



2.8.7 Hot components

Many vehicle components, i.e. the engine, gearbox, brakes etc. operate at temperatures high enough to cause skin burns to personnel coming into contact with a recently operated engine unit.

Exhaust systems, turbochargers, catalytic converters and their components can reach extremely high temperatures.

To avoid the risk of skin burns, allow the vehicle component to cool before carrying out any work.

Take care to avoid contact with hot components, particularly exhaust system components, and fluids, such as hydraulic system oil, on a vehicle when carrying out tests with the engine running.

2.8.8 'Live' work

It is sometimes necessary to perform adjustments to the vehicle with the engine and vehicle systems 'live' (running).

1. Take great care when carrying out any 'live' (running) operations and adjustments.
2. Where possible, have an assistant standing by in a position where they can stop the engine or vehicle system in an emergency.
3. Locate and check the operation of all 'Emergency stop' push-buttons before starting any 'live' work.

2.8.9 Fasteners

When assembling/refitting components using fasteners such as torque loaded bolts, nyloc nuts or split pins etc., always use new fasteners. Do not re-use old fasteners except where specifically mentioned in the text.

2.8.10 Protecting vehicle components during grinding, drilling and welding

When grinding, drilling and welding or similar, take appropriate precautions to prevent damage to pipes, hoses, wiring, glazing, cab paintwork and rubber suspension parts.

1. Shield vulnerable components from the sparks and heat generated by grinding and welding.
2. If protection by shielding is not possible, remove vulnerable components.



Caution:

If drilling holes, be aware of electrical components behind the place where you are drilling. Do not allow swarf to fall onto electrical components, as this can result in electrical short circuits.

Vehicles may be equipped with an automatic chassis lubrication system, involving a number of additional pipes. These pipes are made from plastic, and are readily damaged. Refer to the chassis manufacturer's manuals for further information.

2.8.11 Welding on or near the vehicle

Exercise extreme care when carrying out welding operations. Electric arc welding can cause serious damage to any electronic items fitted to the vehicle.

1. Always stop the engine and disconnect the batteries and electronic units in the approved sequence (Refer to chassis-cab manufacturer's workshop manual for information and instructions) before carrying out any welding repairs.
2. Ensure that the vehicle is not leaking diesel, oil or hydraulic fluids as these may ignite whilst welding.
3. Always have a serviceable fire extinguisher close at hand.
4. Wear eye protection to protect eyes from welding flash.
5. Erect protective screens to protect other personnel from the dangers of the area.



HEALTH AND SAFETY

2

2.8.12 Manual handling and movement of loads

All persons planning the lifting or movement of loads or involved in lifting or movement of loads must obey the requirements of National and Local legislation and regulations.

Many of the vehicle parts are either extremely heavy and/or complicated in shape and size. Attempting to move such components may cause bodily injury.

The approximate weights of major components are listed in the Technical Data section of applicable chapters.

To avoid personal injury or damage to equipment when you work on the vehicle you must obey the following rules.

1. Use correct methods when lifting or carrying items by hand.
2. Use suitable lifting equipment and methods when lifting or moving heavy or large objects.
3. Make sure that lifting equipment has been inspected and is certified fit for use.
4. Make sure that safety pins, props and stands are positioned correctly before the start of work.
5. Never land any item of equipment in a walkway or clear zone.
6. Keep the work area clean and free from obstruction.
7. Keep any personnel not involved with the procedure at a safe distance.

2.8.13 Access and lifting equipment

Some maintenance tasks require the erection of access platforms and/or lifting equipment to provide a safe, stable platform.

1. Access platforms or lifting equipment must be erected by qualified personnel. Under no circumstances must unqualified personnel erect or alter such equipment.
2. Access platforms and lifting equipment must be regularly inspected for continued serviceability.

2.8.14 Cleaning of equipment

1. Do not attempt to clear blockages or remove damaged items whilst the equipment is running.
2. Keep fingers, hair and loose clothing away from moving parts.
3. Do not attempt to climb or reach over guards.

2.8.15 Environmental protection precautions

1. Contact the Local Government Authority or Environmental Protection Agency for advice or disposal facilities.
2. Collect and dispose of used oil carefully.
3. Mop up all spillages.
4. Do not burn used hydraulic oil, rubbers, plastics or polyurethane foams.
5. Dispose of used oil through authorized waste disposal contractors.

2.8.16 Fuel, oil, lubricants, degreasants and filters

Long term exposure of the skin to diesel fuel, lubricating oils, hydraulic oil, lubricants and degreasants can cause problems such as dermatitis. Waste oil is a known carcinogenic material and both air and oil filters collect material that can be hazardous to health. To reduce risk to you, other people and the environment, work to the guidelines given below.

1. Always obey local and national legislation about collection and disposal of waste diesel fuel, lubricating oils, hydraulic oil and lubricants.
2. Take care to collect and dispose of diesel fuel, lubricating oils, hydraulic oil and lubricants carefully and properly. Contact the supplier or your local authority for information about collection depots.

NEVER pour diesel fuel, lubricating oils, hydraulic oil and lubricants onto the ground, into water or down drains or sewers. Discarded diesel fuel, lubricating oils, hydraulic oil and lubricants will damage groundwater quality.

3. Collect and dispose of diesel fuel and hydraulic oil carefully. Contact the point of sale, supplier or local authority for information about collection depots.
4. Filter inserts and cartridges are hazardous waste materials and must be disposed of correctly. Follow instructions issued by the relevant local authority for disposal. Wear a filter mask when you work on contaminated filters.
5. Avoid lengthy, excessive or repeated skin contact with diesel fuel, lubricating oils, hydraulic oil and lubricants. Protect exposed skin with suitable barrier agent or protective clothing.
6. Use an approved cleaning agent to clean ALL areas of skin that have come into contact with diesel fuel, lubricating oils, hydraulic oil and lubricants.
7. Do not wear oil soaked garments next to the skin.
8. Avoid breathing oily mists.

2.8.17 Solvents

Take special precautions when working with solvents, such as during cleaning and degreasant operations. Only use these materials in a well ventilated area.



2.8.18 Contact with plastic material residues after fires

Most modern plastic materials release toxic gasses when they burn. The burnt residue can contain toxic and corrosive material and liquids, especially after contact with water or in humid atmospheres.

When work is done on any part of the vehicle that is contaminated with burnt or degraded plastics, use the following precautions:

1. Do not touch burnt or degraded materials.
2. Let all materials cool down and dry before work starts.
3. Wear protective clothing, with PVC or Neoprene protective gloves. Breathing apparatus may be needed in confined spaces.
4. Treat contaminated parts, clothing and cleaning materials as toxic waste and dispose of them in accordance with local and national regulations.

2.9 Cleaning a bodywork

1. Wear protective clothing, gloves and goggles when you clean an Olympus Twin Pack refuse collection bodywork. Loose debris may be ejected from the body and tailgate.
2. Never enter the body or tailgate unless the 'Body main' key operated switch is in the off position with the key removed (see Olympus Twin Pack Operator's Handbook, Chapter 4 Operator's Controls), the engine is stopped, the ignition key is removed, all cab doors are locked with the keys removed and you are in possession of all the removed keys, and any spare keys.
3. Be aware of dangerous refuse such as glass and hypodermic needles.
4. Do not climb into the tailgate to clean debris unless you know and can work to the safe working procedures given in this Workshop Manual.
5. Never clean the seal area between the tailgate and body unless the tailgate is fully propped.

2.9.1 Pressure washing



WARNING:
DO NOT DIRECT PRESSURE WASHER AT A PERSON. HIGH-PRESSURE WATER JETS CAN CAUSE INJURY.



Caution:
High-pressure water jets can cause severe damage to electrical equipment.

1. When pressure washing do not allow the jet nozzle to approach closer than 1 metre.
2. Whenever possible do not direct the jet straight at components, but aim across them.
3. Do not direct the jet at electrical components.



HEALTH AND SAFETY

2

2.10 Vehicle electrical systems

2.10.1 General electrical precautions

1. Always ensure correct polarity when making cable connections.
2. Before using any test equipment always read the manufacturer's instructions.
3. Do not pierce any electrical leads or looms with test probes, etc.
4. Ensure that no arcing takes place between electrical connections.
5. Always ensure that electrical components, wiring looms and harnesses are correctly fitted and connected. Incorrect fitting, incorrect connections, additions or alterations to an electrical system could create a risk of injury and fire.
6. Always remove all personal jewellery, e.g. rings, watches, chains etc., before commencing work on the electrical system even if the battery is disconnected.
7. Never guess the polarity of connections or wiring, use a voltmeter and refer to circuit diagrams.
8. Use good quality electrical test meters when carrying out tests. A poor meter can affect the results you obtain and may damage electronic components.
9. Only use slave battery sets incorporating an isolator switch to start the vehicle.
10. Only use batteries with a combined total voltage of 24 V, or a vehicle with a 24 V electrical system. Failure to do so will result in extensive damage to the equipment.

2.10.2 Disconnection and reconnection of electrical components

1. Note the position of all the connectors before they are removed.
2. When reconnecting components, ensure connectors are refitted in the same positions as noted on removal. If in doubt refer to the relevant circuit wiring diagram.
3. If renewing halogen type bulbs do not touch the bulb glass with the fingers. If necessary, wipe the glass clean using a cloth moistened in denatured alcohol (methylated spirit).
4. If renewing fuses, always switch off the affected circuit first and fit a new fuse of the correct ampere rating, (refer to label on fuse box cover or fuse list in vehicle Operator's Handbook or Workshop Manual if in doubt). If the new fuse also fails, investigate the cause and rectify.



Caution:
DO NOT use a fuse with a higher ampere rating than specified, and under no circumstances bridge the fuse terminals with anything other than a fuse. Non-observance of the latter may cause components to be damaged and/ or wiring to overheat, leading to a fire.

2.11 Welding on or near the vehicle

Exercise extreme care when carrying out welding operations. Electric arc welding will seriously damage any electronic items fitted to the vehicle.

1. Always stop the engine and disconnect the batteries and electronic units in the approved sequence (Refer to chassis-cab manufacturer's workshop manual for information and instructions) before carrying out any welding repairs.
2. Ensure that the vehicle is not leaking diesel, oil or hydraulic fluids as these may ignite whilst welding.
3. Always have a serviceable fire extinguisher close at hand.
4. Wear eye protection to protect eyes from welding flash.

Erect protective screens to protect other personnel from the dangers of the area.



2.12 Hydraulic and pneumatic systems

Vehicle hydraulic systems operate at high pressures, some parts of the system are under pressure even whilst the vehicle is shut down. Use caution when working on the system and its components.

Compressed air is dangerous when misused, and flexible hoses may whip when under pressure.

1. Before dismantling or breaking into an hydraulic and pneumatic system, shut off the pressurised supply at a remote point and then de-pressurise the system.
2. When disconnecting hydraulic hose connections:
 - Wear a full face visor while loosening the pipe nuts.
 - Cover the connection with a cloth while loosening the pipe nuts to prevent pressurised oil spraying from connection.
3. When working on the hydraulic and pneumatic systems, it is important to ensure maximum cleanliness.
4. Always clean the area around a connection before dismantling a joint.
5. Plug any open connections as soon as possible.
6. Use only lint-free cloths.
7. Wherever possible, avoid using compressed air for cleaning components.

2.13 Returning the vehicle to service

1. At the end of any maintenance work and before returning the vehicle to service, ensure that:
 - All tools, parts materials and debris are removed from the vehicle.
 - Any protective guards removed for access are replaced and correctly secured.
 - The vehicle has completed a Daily Safety Check as described in Chapter 3 of this manual.



This page intentionally left blank



Olympus Twin Pack Service Manual

CONTENTS

PAGE

3	Daily checks.....	3-3
3.1	Daily safety checks.....	3-3
3.2	Warning labels.....	3-28



This page intentionally left blank



3 Daily checks

It is important that your machine is kept in good working order.

The following Daily Safety Checks must be carried out on a Dennis Eagle Ltd. Refuse Collection Vehicle to confirm the correct operation of the machine, its controls, safety circuits and interlocks, in addition to checks specified in the chassis-cab manufacturer's and waste container lifting device manufacturer's service information, before it commences service.

The same checks should also be carried out by service personnel whenever scheduled maintenance service procedures and inspections are carried out or after a minor or major repair has been made to the body.

Make sure that there is no mechanical damage or wear evident in the refuse mechanism, especially in the pivoting and locking of the tailgate to the body.

Any problems must be reported to supervision immediately.

3.1 Daily safety checks

1. Stand the vehicle on clean, level and stable ground with sufficient clearance to allow for the tailgate and waste container lifting device, if fitted, to be fully raised.
2. Engage the parking brakes.
3. Select Neutral 'N'.
4. Stop the engine.
5. Turn the 'Body main' switch to the off position. Remove and retain the key.



6. Switch the ignition off. Remove and retain the key.
7. Lock all cab doors. Remove and retain the keys.
8. Walk around the Refuse Collection Vehicle and:
 - Make sure that there is no refuse, paper or flammable materials near the engine or exhaust. These could cause a fire when the engine is started. If necessary, tilt the cab (See Chassis-cab Manufacturer's Operator's Handbook) to make a thorough inspection.



DAILY CHECKS

3

- Visually check level of oil in hydraulic oil tank. The float in the bottom sight glass should be at the top of the sight glass. If the level is below this report to supervision immediately and do not proceed any further with the daily inspection.

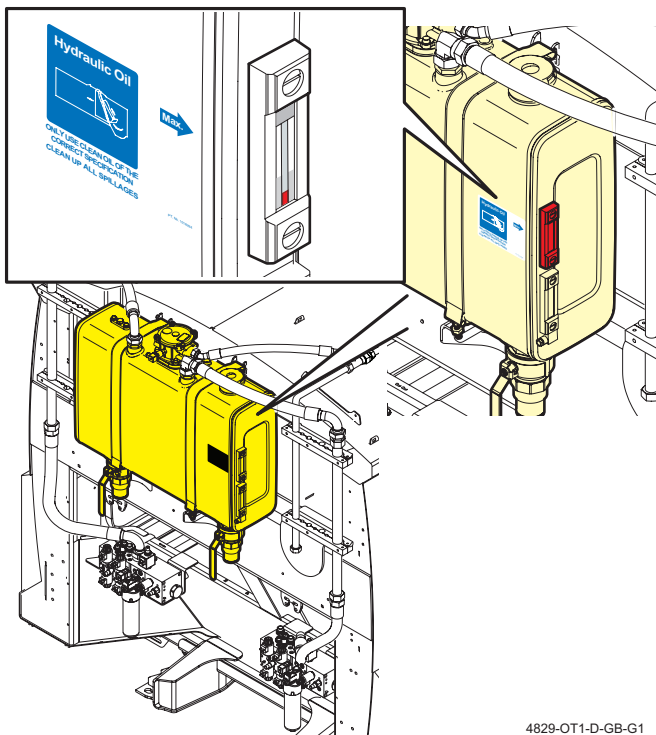
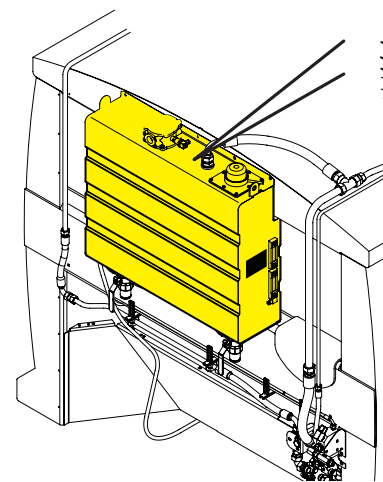
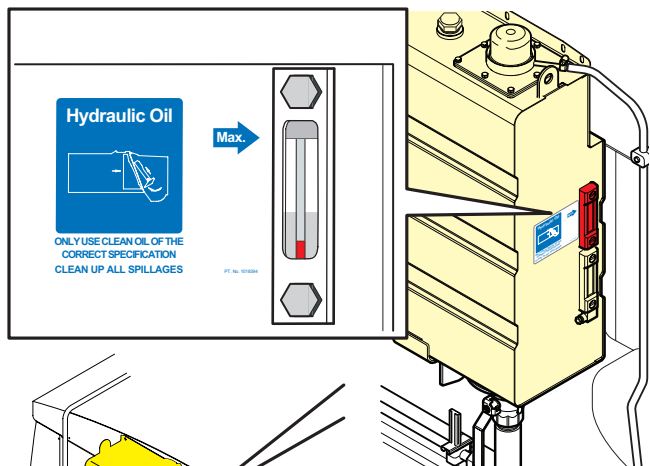

4829-OT1-D-GB-G1

- Visually check for obvious damage to lamps, warning beacons, reflectors and lenses and bodywork.
 - Check that all marking plates and warning instruction labels are complete, clean, clearly visible and readable (see '3.2 Warning labels' on page 3-28).
 - Visually check underneath (BUT DO NOT GO UNDERNEATH THE VEHICLE) the Refuse Collection Vehicle for evidence of hydraulic oil leaks from the body system hydraulic pipes.
 - Visually check the electrical harnesses and connections, hoses, pipes and other components for obvious signs of defects.
9. Arrange for an assistant to observe the operation of body systems and lamps from a safe viewpoint at the rear of the vehicle.
 10. Enter the Refuse Collection Vehicle cab.
 11. Check that all the emergency tools, equipment and fire extinguisher are present.
 12. Check that the first aid kit is complete.



13. Switch the ignition on only, do not start the engine.

- The control screen should initialise and then display the 'Body system off' mode.

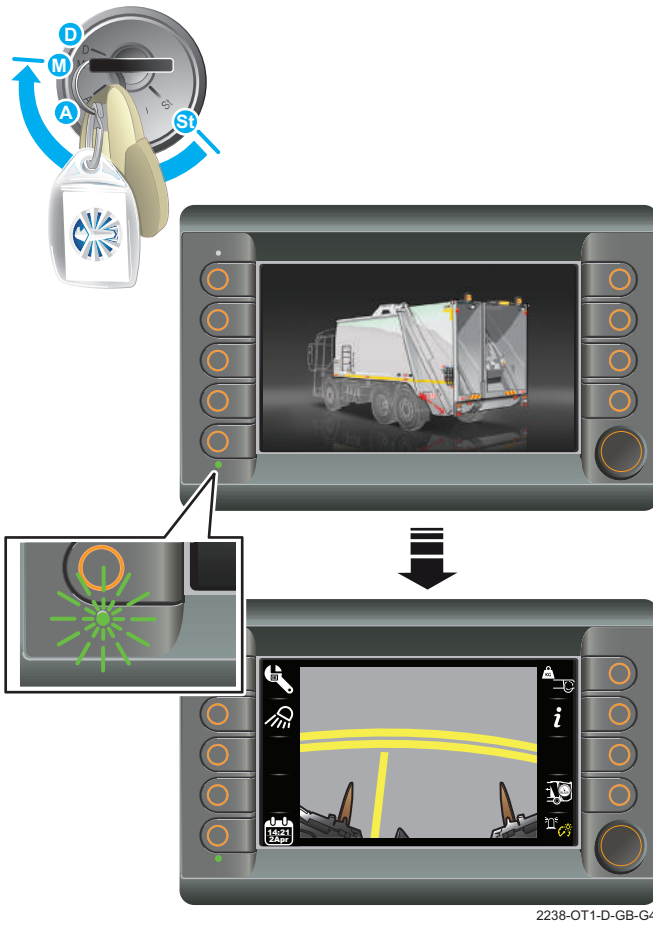

16. Switch on the warning beacons.

- Check that the warning beacons and their associated warning lamps operate correctly when switched on and extinguish when switched off.

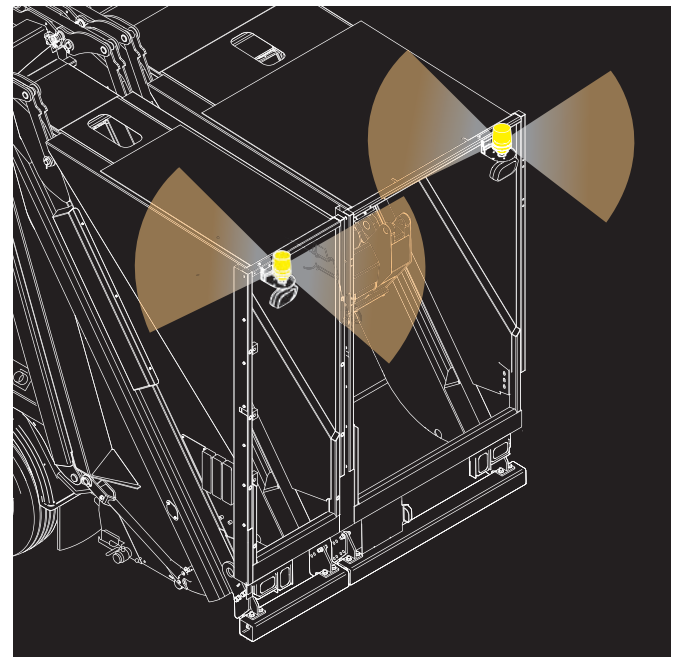
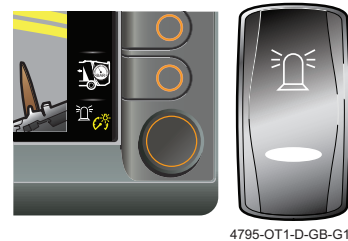

14. Switch on all the vehicle lamps, including fog lamps (if fitted).

- Check that the lamps and their associated warning lamps illuminate when switched on and extinguish when switched off.

15. Operate the footbrake.

- Check that all the brake lamps illuminate when the pedal is pressed and extinguish when the pedal is released.



DAILY CHECKS

17. Make sure that the parking brake is applied and Neutral 'N' is selected.
18. Start the engine, check the warning panels and instrumentation for any indications of system malfunctions.
 - The 'Low air pressure' warning buzzers should not be sounding.
19. Turn the 'Body main' switch on.



- The screen should display the 'Body system run' mode.



2578-OT1-D-GB-G3

- If any warning pictograms are displayed on the screen, report to supervision immediately and do not proceed any further with the daily inspection.



20. Press and release the 'Work lamp' switch.



- Check that the tailgate loading lamps and all the work lamps fitted to the vehicle illuminate.

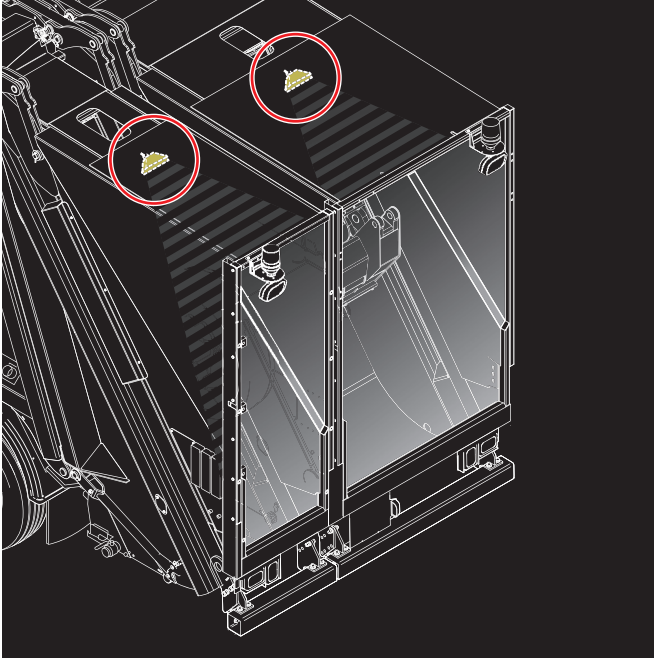

2251-OT1-D-GB-G2



2253-OT1-D-GB-G3

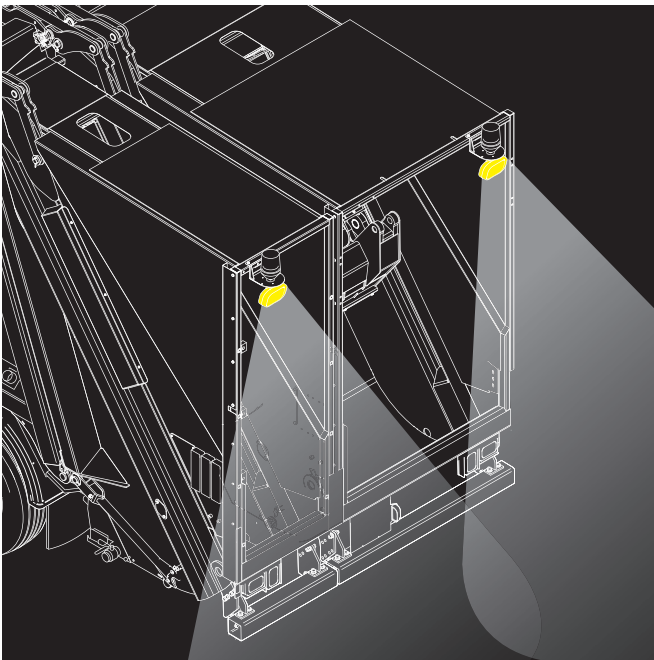

2384-OT1-D-GB-G2



DAILY CHECKS

For each body in turn, carry out operations 21 - 50.

21. Turn the 'Body selector' switch to select the required body, left-hand or right-hand.

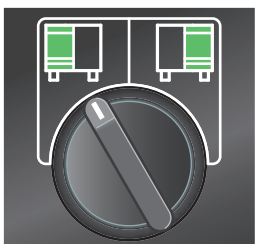

2243-OT1-D-GB-G2

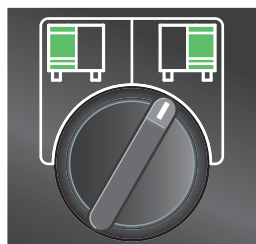

2244-OT1-D-GB-G2

22. Press and release the 'Internal discharge controls' switch.

- The screen should display the 'Body discharge internal controls' mode.

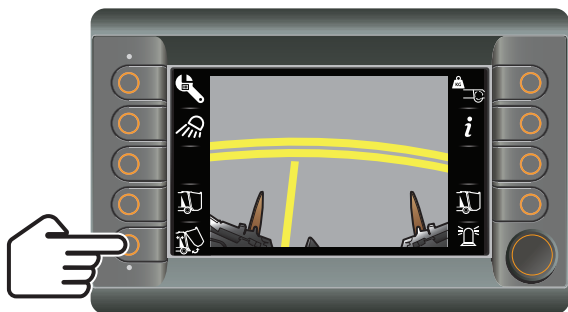

2354-OT1-D-GB-G4

23. Check that 'Tailgate clear' pictogram at the bottom left hand corner is green.

If it is white:

- Press and release the switch beside it and check that the pictogram changes colour to green.
- Report fact to supervision.

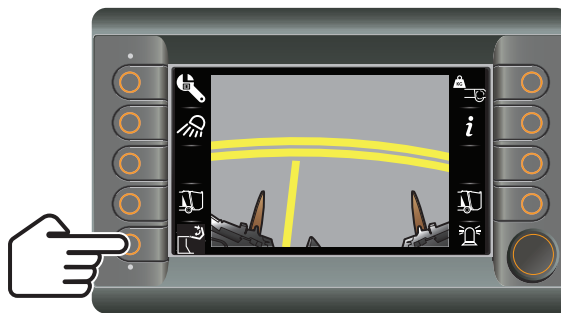

2438-OT1-D-GB-G3



WARNING:
MAKE SURE THAT YOU KNOW THE HEIGHT OF YOUR VEHICLE WITH THE TAILGATE AND WASTE CONTAINER LIFTING DEVICE, IF FITTED, RAISED.



24. Press and hold the 'Tailgate raise' switch until the tailgate is just out of its locks and then release the switch.

- Tailgate should raise smoothly until it is out of the locks.
- 'Vehicle reversing' alarm should sound immediately the tailgate is out of the locks while the 'Tailgate raise' switch is being pressed and the tailgate is rising

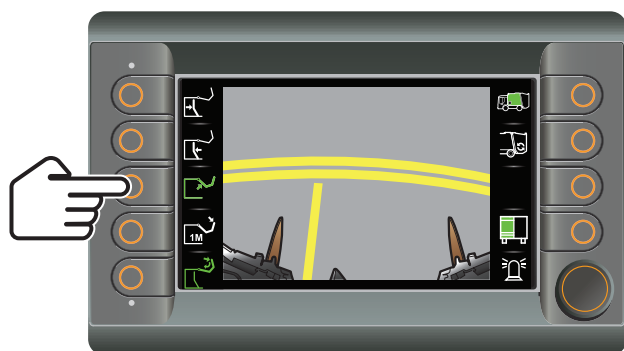

2440-OT1-D-GB-G3

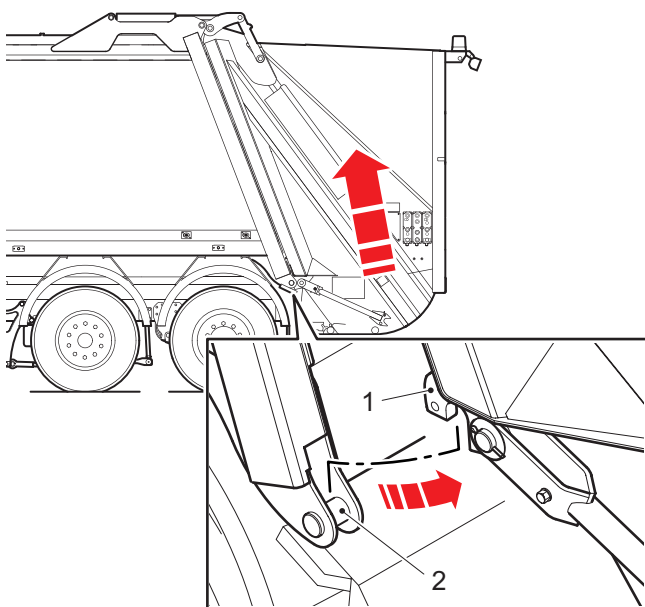

2439-OT1-D-GB-G3

- 'Tailgate out-of-locks' pictogram should display on the control panel screen when 'Tailgate raise' switch is released.



WARNINGS:
MAKE SURE THAT YOU KNOW THE HEIGHT OF YOUR VEHICLE WITH THE TAILGATE AND WASTE CONTAINER LIFTING DEVICE, IF FITTED, RAISED.

DRIVER MUST BE IN CAB.

PARKING BRAKE MUST BE APPLIED.

ALL PERSONNEL MUST BE CLEAR OF FRONT AND REAR OF VEHICLE.

VEHICLE MAY LURCH FORWARDS.

25. Firmly apply the footbrake. Then select Drive 'D'.

- 'Tailgate out-of-locks' warning buzzer in the cab should sound immediately Drive 'D' is selected.

26. Select Neutral 'N'.

- 'Tailgate out-of-locks' warning buzzer in the cab should silence immediately Neutral 'N' is selected.



DAILY CHECKS

3

27. Press and release the 'Body system run controls' switch.

- The screen should display the 'Body system run' mode with 'Tailgate out-of locks' pictogram.



2441-OT1-D-GB-G3

29. On each de-energised 'Start pack cycle' push-button, press and release the 'Start pack cycle' push-button to activate it.

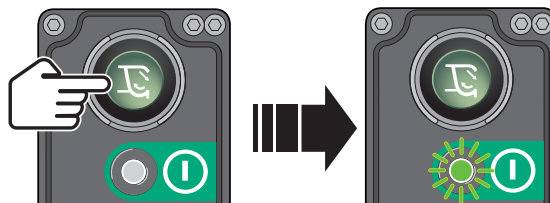

- The green indicator lamp should illuminate.

30. Press in turn the:



Start pack cycle push-button.



Rescue push-button.

2442-OT1-D-GB-G1

- Compaction mechanism should not operate.



WARNING:
COMPACTION MECHANISM MAY OPERATE.
MAKE SURE THAT THE TAILGATE AREA IS CLEAR OF PERSONNEL.

28. On each energised 'Start pack cycle' push-button, press in turn the:



Start pack cycle push-button.



Rescue push-button.

2442-OT1-D-GB-G1

- Compaction mechanism should not operate.



31. Press and release the 'Internal discharge controls' switch.
- The screen should display the 'Body discharge internal controls' mode and 'Tailgate-out-of-locks' pictogram.

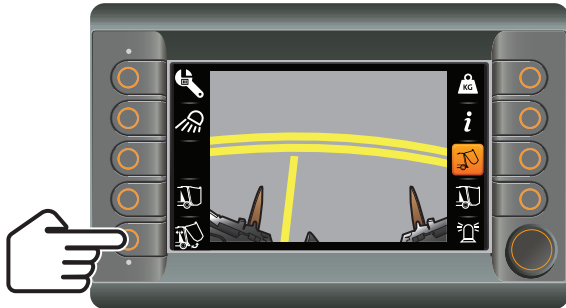

2443-OT1-D-GB-G3



WARNING:
COMPACTION MECHANISM MAY OPERATE.
MAKE SURE THAT THE TAILGATE AREA IS CLEAR OF PERSONNEL.

32. On each compaction mechanism control panel, press in turn the:



Start pack cycle push-button.



2442-OT1-D-GB-G1

Rescue push-button.

- Compaction mechanism should not operate.



WARNING:
MAKE SURE THAT YOU KNOW THE HEIGHT OF YOUR VEHICLE WITH THE TAILGATE AND WASTE CONTAINER LIFTING DEVICE, IF FITTED, RAISED.

33. Press and hold the 'Tailgate raise' switch.

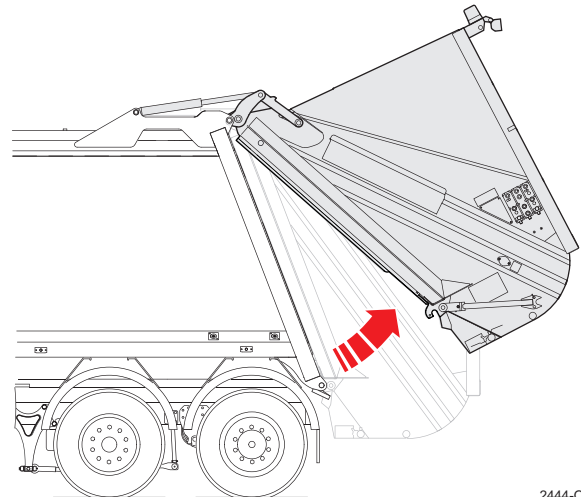
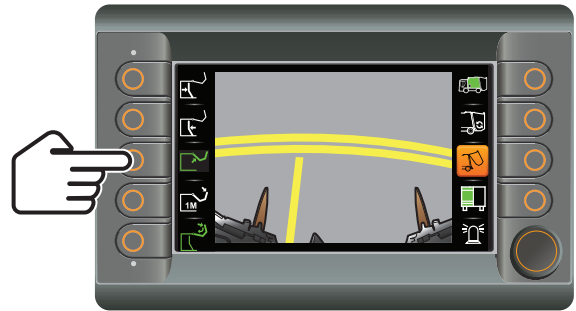

2444-OT1-D-GB-G3

- Tailgate should rotate smoothly upwards about the hinge pins.
- 'Vehicle reversing' alarm should sound.



DAILY CHECKS

3

34. While tailgate is rising, release the 'Tailgate raise' switch before it reaches its fully raised position.

- Tailgate should stop rising immediately the switch is released.
- Tailgate should not lower.
- 'Tailgate out-of-locks' pictogram should display on the control panel screen.



2440-OT1-D-GB-G3

- When the tailgate is raised, the 'Tailgate fully raised' pictogram should display on the control panel screen.



2575-OT1-D-GB-G3

- 'Vehicle reversing' alarm should silence.

35. Press and hold the 'Tailgate raise' switch until the tailgate is fully raised and then release the switch.

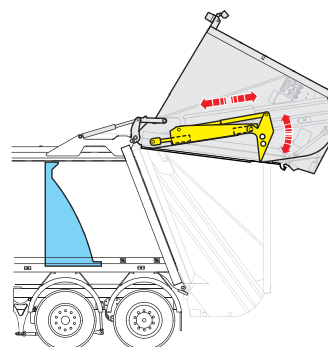
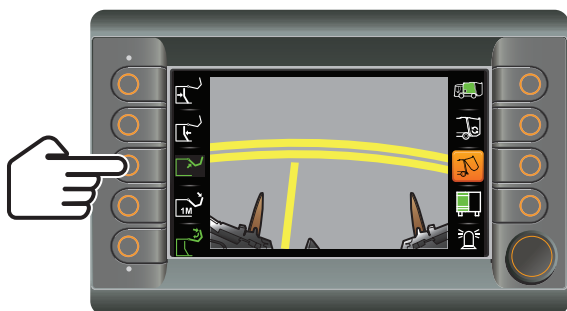

2446-OT1-D-GB-G2

- Immediately the tailgate reaches full height, the compaction mechanism should complete one full cycle, i.e. packer plate open, carriage plate down, packer plate close and then carriage plate up in one continuous sequence until fully packed when it should stop.



WARNINGS:
MAKE SURE THAT YOU KNOW THE HEIGHT OF YOUR VEHICLE WITH THE TAILGATE AND WASTE CONTAINER LIFTING DEVICE, IF FITTED, RAISED.

DRIVER MUST BE IN CAB.

PARKING BRAKE MUST BE APPLIED.

ALL PERSONNEL MUST BE CLEAR OF FRONT AND REAR OF VEHICLE.

VEHICLE MAY LURCH FORWARDS.

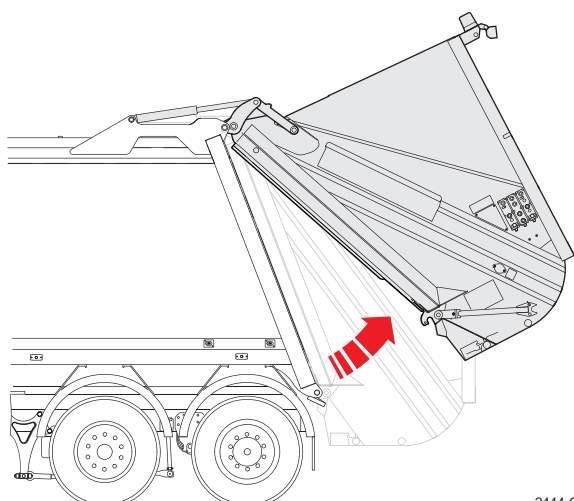

2444-OT1-D-GB-G3

- Tailgate should resume rotating upwards about the hinge pins until fully raised when it should stop without noticeable judder.
- 'Vehicle reversing' alarm should sound while 'Tailgate raise' switch is being pressed and the tailgate is rising.



- 36. Firmly apply the footbrake. Then select Drive 'D'.
 - 'Tailgate out-of-locks' warning buzzer in the cab should sound immediately Drive 'D' is selected.
- 37. Select Neutral 'N'.
 - 'Tailgate out-of-locks' warning buzzer in the cab should silence immediately Neutral 'N' is selected.
- 38. Press the 'Eject' switch. Release the switch when the ejection plate has reached the end of its travel.

- 39. Press the 'Retract' switch. Release the switch when the ejection plate has reached the end of its travel.

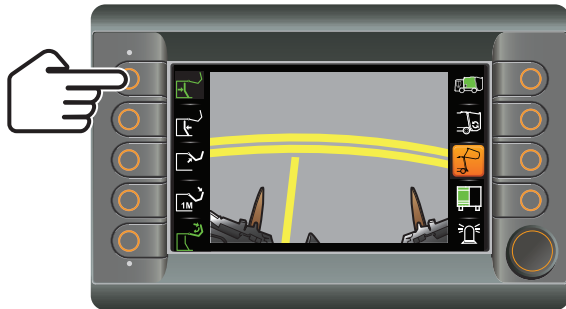

2447-OT1-D-GB-G3

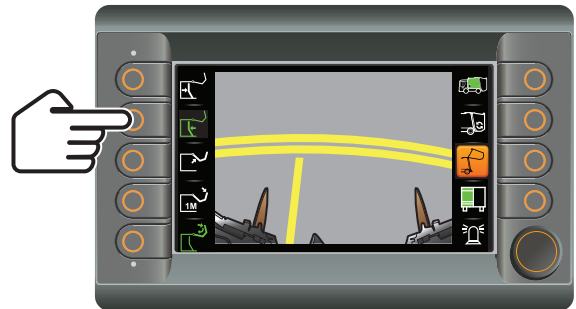

2449-OT1-D-GB-G3

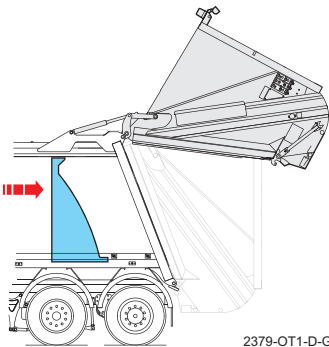

2379-OT1-D-GB-G2

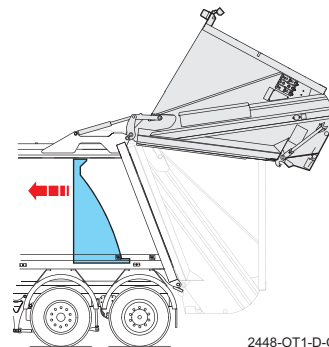

2448-OT1-D-GB-G1

- Ejection plate should eject smoothly without judder.

- Ejection plate should retract smoothly without judder.



DAILY CHECKS

3

40. Press the 'Eject' switch. Release the switch when the ejection plate has reached the end of its travel.

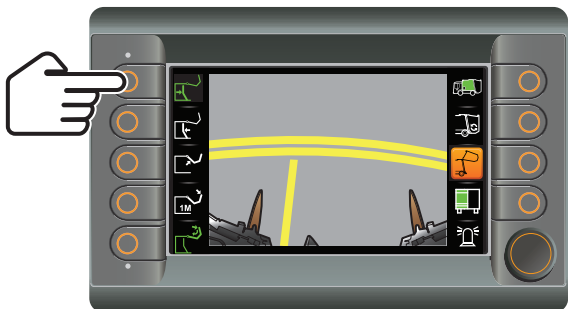

2447-OT1-D-GB-G3

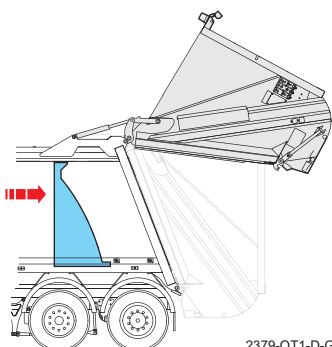

2379-OT1-D-GB-G2

42. Press the two push-buttons on the 'Tailgate lowering' control panel simultaneously.

- Tailgate should lower smoothly without judder.

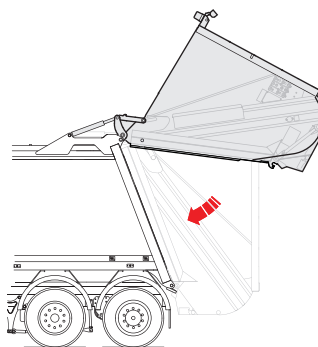

2451-OT1-D-GB-G2

- 'Vehicle reversing' alarm should sound.
- The engine speed should lower to tick-over.



WARNING:
MAKE SURE THAT THE TAILGATE AREA IS CLEAR OF PERSONNEL.

41. Press each of the two push-buttons on the 'Tailgate lowering' control panel separately.

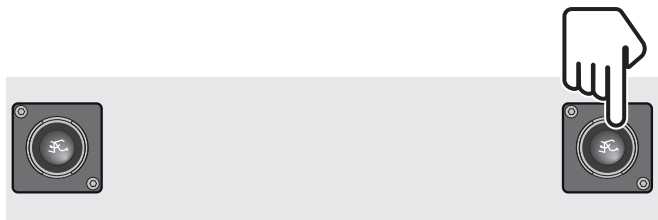

2450-OT1-D-GB-G1

- Tailgate should not lower.



43. While tailgate is lowering, release one of the push-buttons but keep the other push-button depressed.

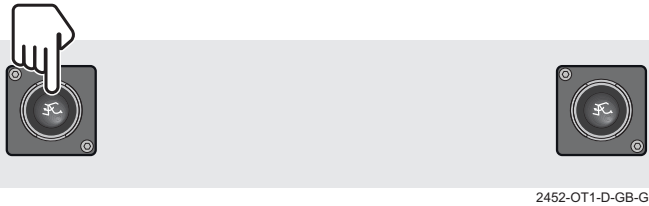

2452-OT1-D-GB-G1

- Tailgate should stop lowering immediately the push-button is released.
- Tailgate should not lower.
- 'Tailgate out-of-locks' pictogram should display on the control panel screen.

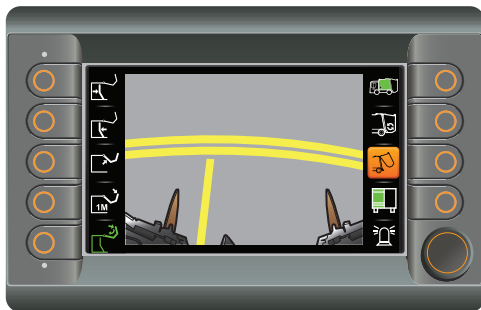

2440-OT1-D-GB-G3

- 'Vehicle reversing' alarm should silence.

44. While keeping the push-button depressed, press the released push-button again.

- Tailgate should remain stationary.
- 'Tailgate out-of-locks' pictogram should continue to display on the control panel screen.

Release both push-buttons.

45. Press the two push-buttons on the 'Tailgate lowering' control panel simultaneously until the tailgate engages locks and then release the push-buttons.



2387-OT1-D-GB-G1

- Tailgate should rotate smoothly downwards about the hinge pins until it engages face of body, then lower into locks.
- 'Vehicle reversing' alarm should sound until the tailgate engages locks when it should silence.

46. Check that the 'Tailgate clear' pictogram in the bottom left-hand corner of the screen is green.

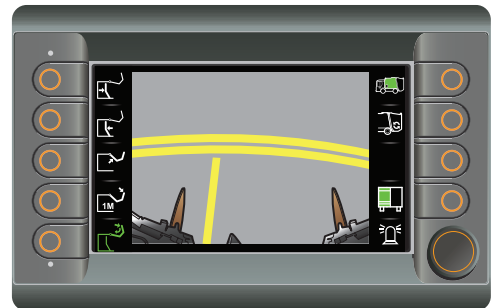

2453-OT1-D-GB-G3

47. Press and release the 'Tailgate clear' switch.

- Check that the pictogram changes to white.

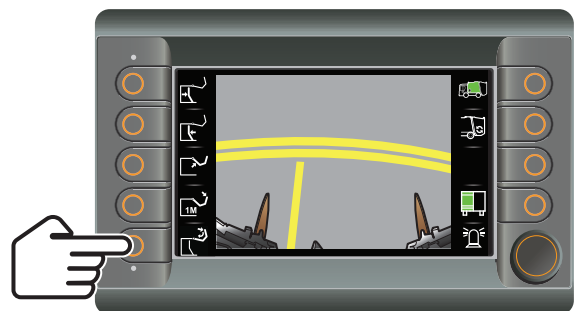

2454-OT1-D-GB-G3



DAILY CHECKS

48. Press and hold the 'Tailgate raise' switch until the tailgate is fully raised and then release the switch.

3

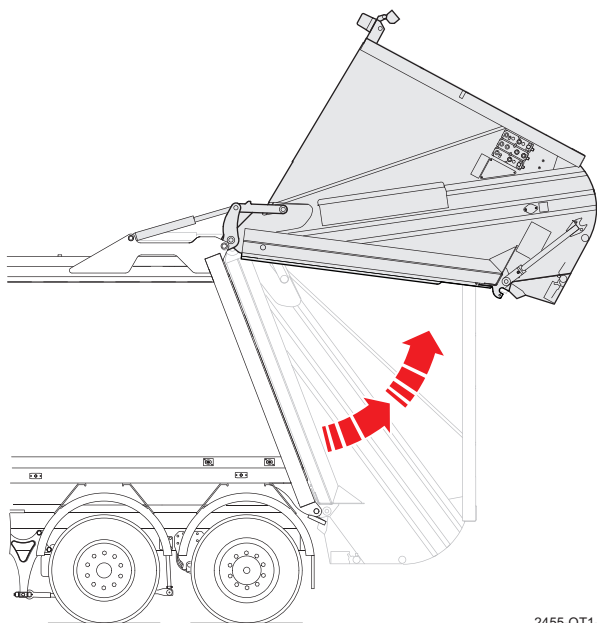
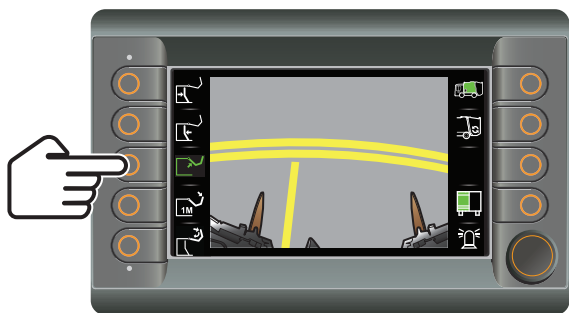

2455-OT1-D-GB-G3

- Tailgate should raise until fully raised when it should stop without noticeable judder.
- 'Vehicle reversing' alarm should sound while tailgate is rising.
- Immediately the tailgate reaches full height, the compaction mechanism should not operate.

49. Press and hold 'Lower tailgate to 1 metre' switch until the tailgate stops lowering and then release the button.

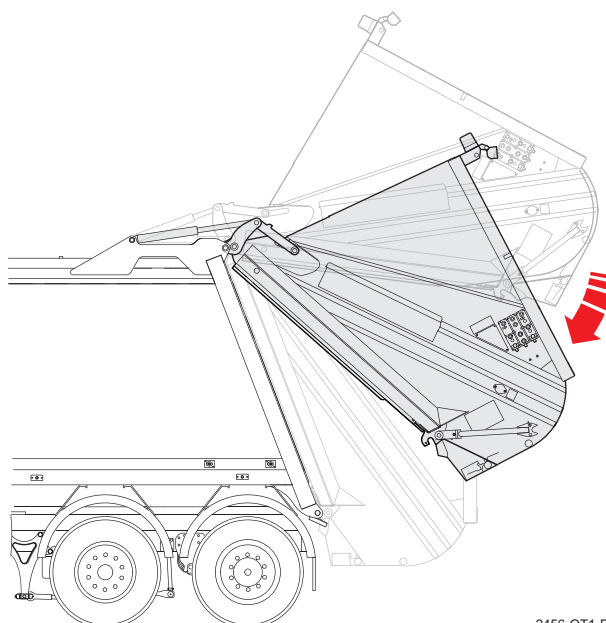
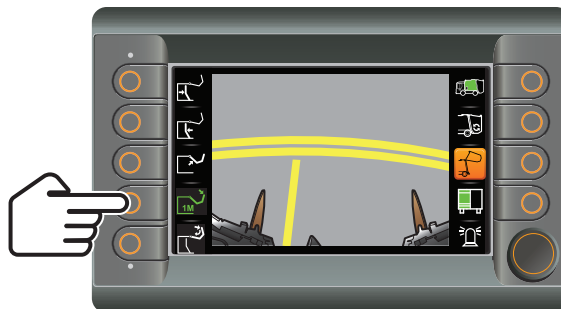

2456-OT1-D-GB-G3

- Tailgate should rotate smoothly downwards about the hinge pins until it is 1 metre from the body when it should stop without noticeable judder.
- 'Vehicle reversing' alarm should sound while tailgate is lowering.
- 'Tailgate out-of-locks' pictogram should display on the control panel screen.



2457-OT1-D-GB-G3



50. Press the two push-buttons on the 'Tailgate lowering' control panel simultaneously until the tailgate engages locks and then release the push-buttons.

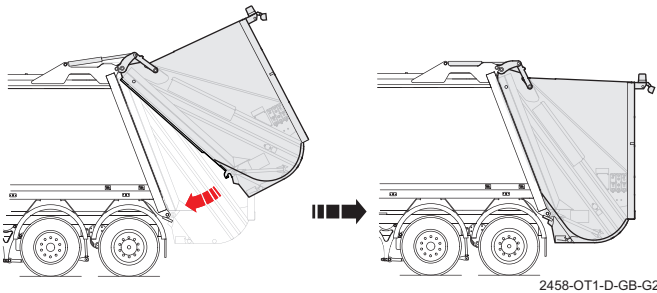
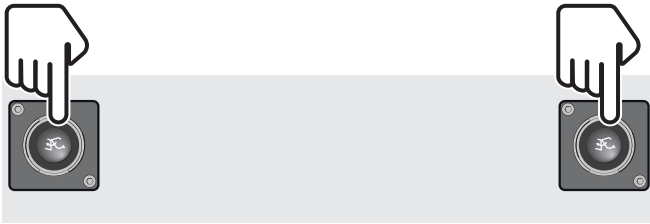

- Tailgate should rotate smoothly downwards about the hinge pins until it engages face of body, then lower into locks.
- 'Vehicle reversing' alarm should sound until the tailgate engages locks when it should silence.

51. Press and release the 'Body system run controls' switch.

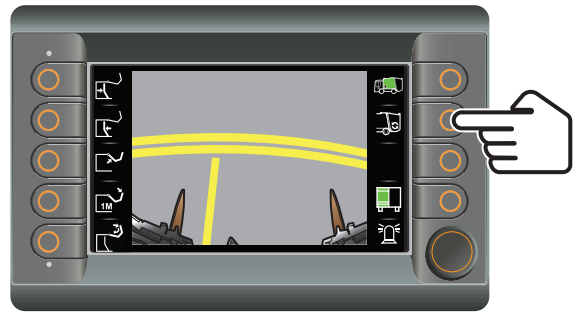

- The screen should display the 'Body system run' mode.



**WARNINGS:
DRIVER MUST BE IN CAB.**

PARKING BRAKE MUST BE APPLIED.

**ALL PERSONNEL MUST BE CLEAR OF
FRONT AND REAR OF VEHICLE.**

VEHICLE MAY LURCH FORWARDS.

52. Firmly apply the footbrake. Then select Drive 'D'.



DAILY CHECKS

3

53. Assistant to press 'Start pack cycle' push-button on each compaction mechanism control panel.

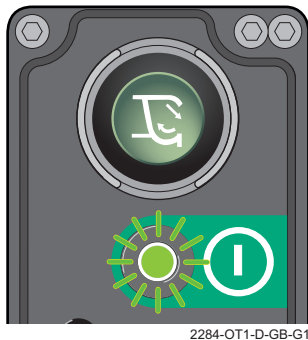

- Compaction mechanism packer plate should open (1), carriage plate and packer plate should move downwards (2), packer plate should close (3), carriage plate and packer plate should move upwards (4) and automatically stop in the packed position.

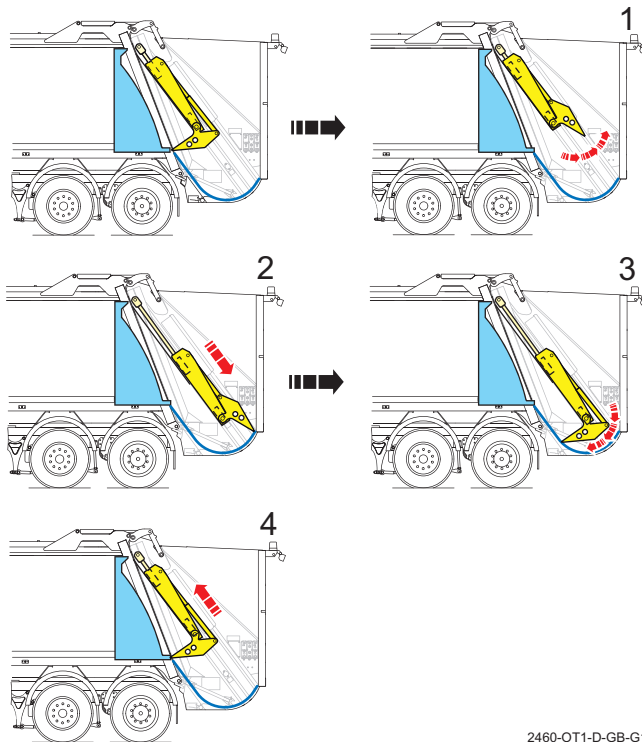

2460-OT1-D-GB-G1

- Compaction mechanism should not operate.

54. Select Neutral.

For each compaction mechanism control panel, carry out the following operations (55 - 60):

55. Check that pack cycle operates correctly according to variant.

Vehicles fitted with a closed waste container lifting device.

Vehicles fitted with an open waste container lifting device and guide plate in raised position.

Vehicles fitted with an open waste container lifting device and a fixed extended rave rail.

Energise each 'Start pack cycle' push-button in turn and then press and release the 'Start pack cycle' push-button.

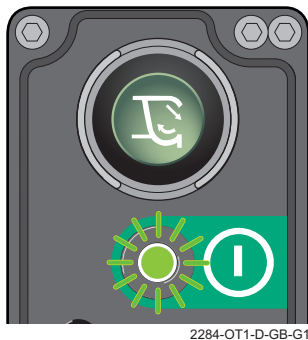

- Green LED below push-button should be illuminated.



Open System vehicles (no waste container lifting device fitted).

Vehicles fitted with an open waste container lifting device and guide plate in lowered position.

56. Press and release the 'Start pack cycle' push-button.

- Packer plate should open and then stop.

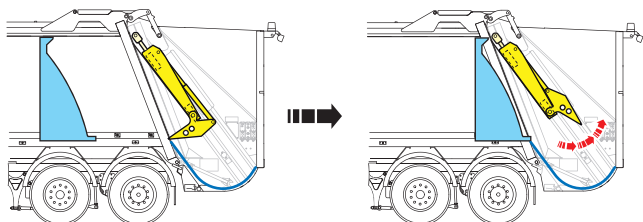
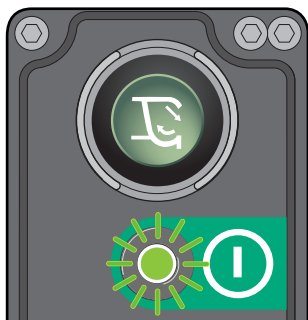

2461-OT1-D-GB-G1

57. Press and hold the 'Start pack cycle' push-button.

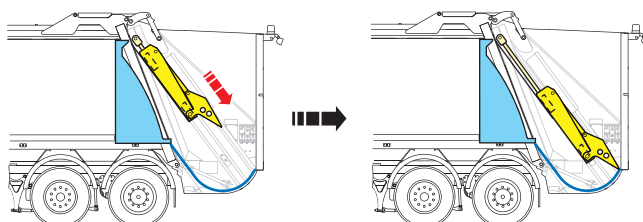
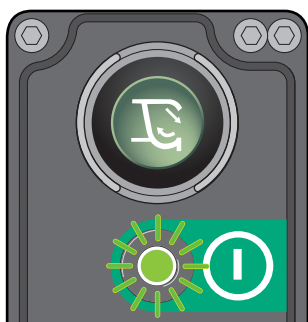

2462-OT1-D-GB-G1

- Carriage plate and packer plate should move downwards.

Release the push-button while the carriage plate and packer plate are moving downwards.

- Carriage plate and packer plate should stop immediately.

58. Press and hold the 'Start pack cycle' push-button again.

- Carriage plate and packer plate should continue to move downwards from stopped position and stop when carriage plate fully lowered.

59. Press and hold the 'Start pack cycle' push-button again.

- The packer plate should close.

Release the push-button after the packer plate has started to close.

- Packer plate should automatically close and then the carriage plate and packer plate should move upwards until the compaction mechanism is fully packed when it should stop.

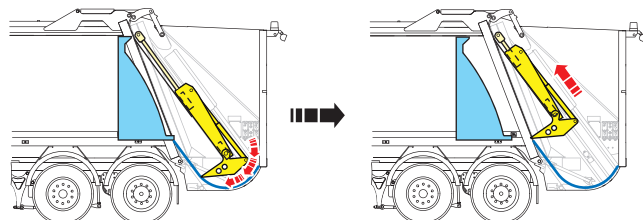

2576-OT1-D-GB-G1



DAILY CHECKS

60. Press and release the 'Signal' push-button.

- 'Tailgate signal' buzzer in the cab should sound immediately the push-button is pressed and silence immediately the push-button is released.



2278-OT1-D-GB-G1

- The 'Signal' warning pictogram should display on the control panel screen while the button is pressed.

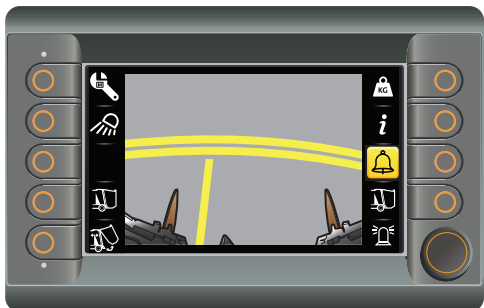

2464-OT1-D-GB-G3

For each 'Emergency stop' push-button:

- Cab control panel (x 1)
- Compaction mechanism control panel (x 2)
- Rave rail or lifting device (x 2)

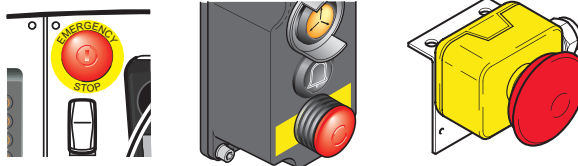

3887-OT1-D-GB-G2

Carry out the following operations (61 - 68):

61. Press a 'Start pack cycle' push-button, to operate the compaction mechanism so that carriage plate is moving upwards.

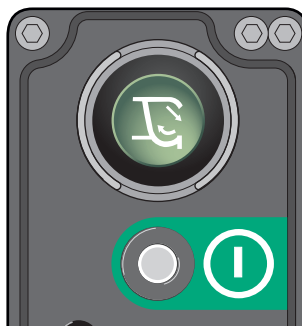

2280-OT1-D-GB-G1

While the carriage plate is moving upwards, press the 'Emergency stop' push-button.

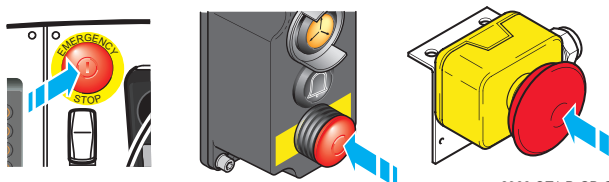

2366-OT1-D-GB-G3

- Compaction mechanism should stop immediately.
- 'Emergency stop' warning buzzer in the cab should sound.
- 'Emergency stop operated' pictogram should display in the control panel screen.



2465-OT1-D-GB-G3



62. On each compaction mechanism control panel, press in turn the:

'Start pack cycle' push-button.

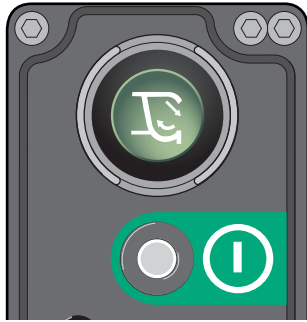

2280-OT1-D-GB-G1

- Compaction mechanism **should not operate.**

'Signal' push-button.

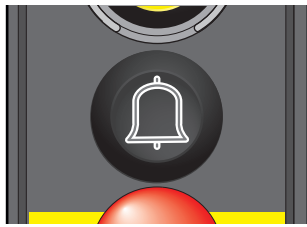

2278-OT1-D-GB-G1

- 'Tailgate signal' buzzer in the cab **should not sound.**

'Rescue' push-button.



2279-OT1-D-GB-G1

- Packer plate should open and carriage plate move upwards simultaneously until it is fully open and fully unpacked.

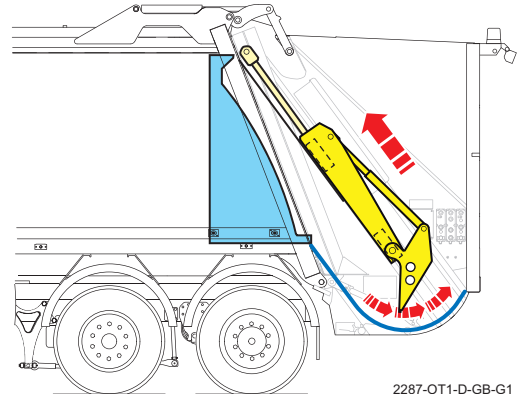

2287-OT1-D-GB-G1

- The 'Rescue' warning pictogram should display on the control panel screen.



2467-OT1-D-GB-G3

63. Turn the 'Body main' switch off and then on again.

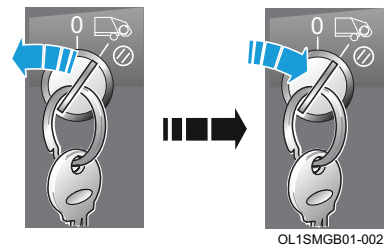

OL1SMGB01-002

64. Pull the 'Emergency stop' push-button outwards.

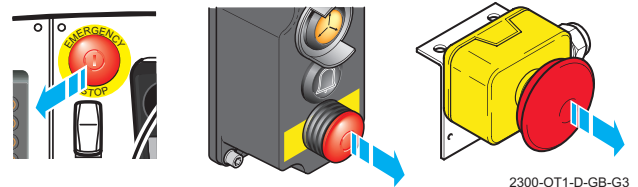

2300-OT1-D-GB-G3

- 'Emergency stop' warning buzzer in the cab should silence.



DAILY CHECKS

3

65. Press the 'Start pack cycle' push-button.

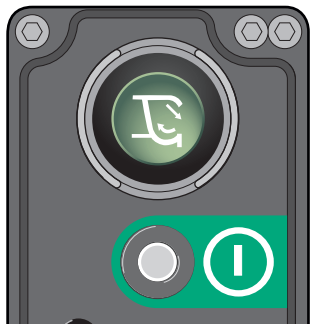

2280-OT1-D-GB-G1

- Compaction mechanism **should not operate.**

66. Turn the 'Body main' switch off and then on again.

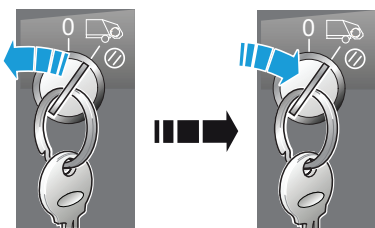

OL1SMGB01-002

67. Press the 'Start pack cycle' push-button.

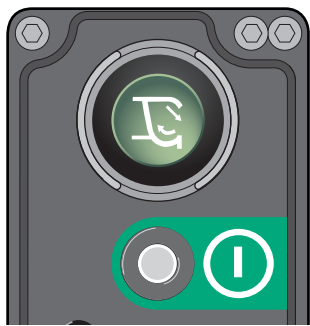

2280-OT1-D-GB-G1

- Check that the compaction mechanism restarts and operates to specification.

68. Turn the 'Body main' switch to off position. Remove and retain the key.



69. Open the left-hand body access door.

70. Insert the key into the 'Body main' switch and turn it to run.



- 'Body access door open' warning pictogram should display in the control panel screen.



2468-OT1-D-GB-G3

71. On each compaction mechanism control panel, press in turn the:

'Start pack cycle' push-button twice.

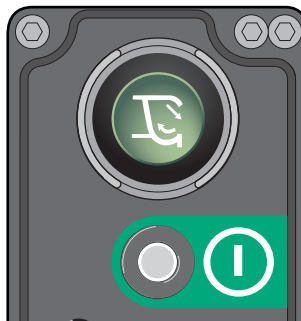

2280-OT1-D-GB-G1

'Rescue' push-button.

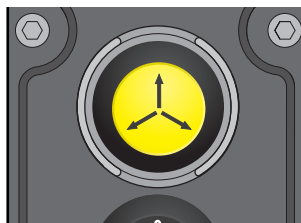

2279-OT1-D-GB-G1

- Compaction mechanism **should not operate.**



72. Press and release the 'Internal discharge controls' switch.
- The screen should display the 'Body discharge internal controls' mode.
 - 'Body access door open' pictogram should continue to display on the control panel screen.

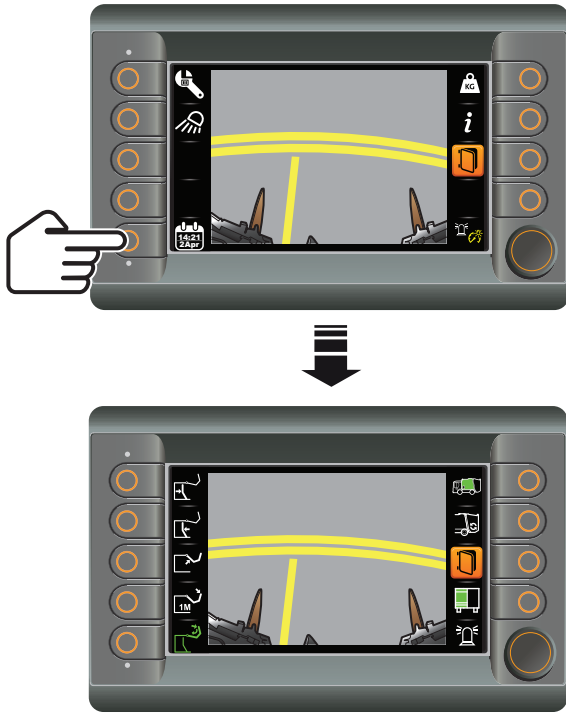

2469-OT1-D-GB-G3



WARNING:
COMPACTION MECHANISM MAY OPERATE.
MAKE SURE THAT THE TAILGATE AREA IS
CLEAR OF PERSONNEL.



WARNING:
MAKE SURE THAT YOU KNOW THE HEIGHT
OF YOUR VEHICLE WITH THE TAILGATE
AND WASTE CONTAINER LIFTING DEVICE,
IF FITTED, RAISED.

73. Press and hold in turn the 'Tailgate raise', 'Ejection plate eject' and 'Ejection plate retract' switches.
- Tailgate raise, ejection plate eject and ejection plate retract functions should not operate.

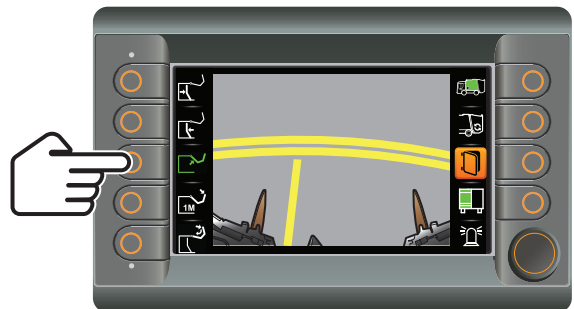
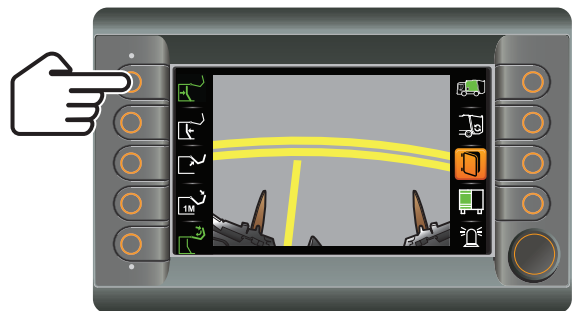
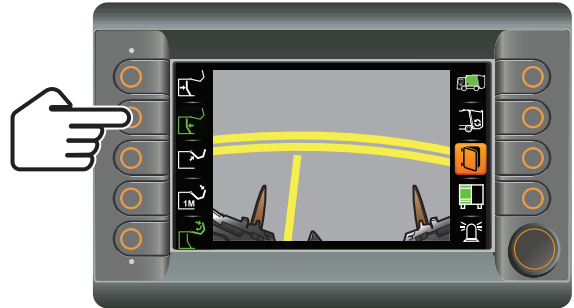

2470-OT1-D-GB-G3



DAILY CHECKS

3

74. Turn the 'Body main' switch to off position. Remove and retain the key.



- 75. Close and lock the left-hand body access door.
- 76. Open the right-hand body access door.
- 77. Repeat operations 70-75 with the right-hand body access door open.
- 78. Insert the key into the 'Body main' switch and turn it to run.



On vehicles fitted with an external discharge control panel carry out the following operations (79-89):

79. Turn the 'Body selector' switch to select the required body, left-hand or right-hand.

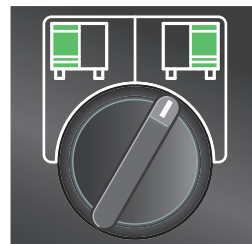
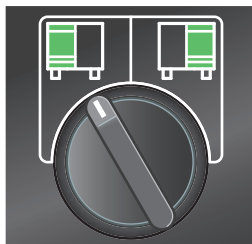

80. Press and release the 'Internal discharge controls' switch.

- The screen should display the 'Body discharge internal controls' mode.

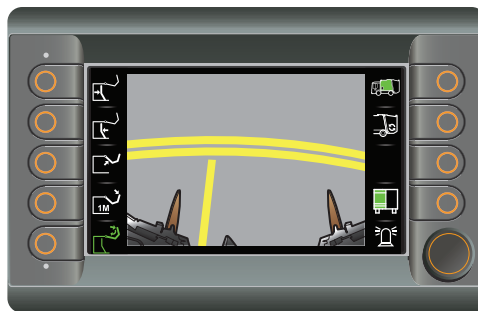

2354-OT1-D-GB-G4



81. Press and release the 'External discharge controls' switch.

- The screen should display the 'Body discharge external controls' mode.



2357-OT1-D-GB-G3



WARNING:
MAKE SURE THAT YOU KNOW THE HEIGHT
OF YOUR VEHICLE WITH THE TAILGATE
AND WASTE CONTAINER LIFTING DEVICE,
IF FITTED, RAISED.

82. Press the 'Tailgate raise' push-button.

- Tailgate should raise smoothly until out-of-locks and then rotate smoothly upwards about the hinge pins.
- 'Vehicle reversing' alarm should sound immediately the tailgate is out-of-locks and while tailgate is rising.

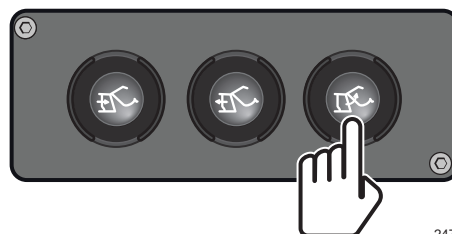
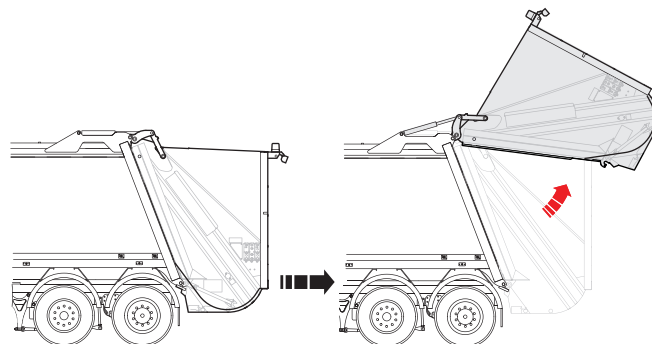

2471-OT1-D-GB-G2

- 'Tailgate out-of-locks' pictogram should display on the control panel screen.



2472-OT1-D-GB-G3



DAILY CHECKS

3

83. While tailgate is rising, release push-button before it reaches its fully raised position.

- Tailgate should stop rising immediately the switch is released.
- Tailgate should not lower.
- 'Tailgate out-of-locks' pictogram should continue to display on the control panel screen.



2472-OT1-D-GB-G3

84. Press the 'Tailgate raise' push-button until the tailgate is fully raised and then release the push-button.

- Check that the tailgate resumes rotating upwards about the hinge pins until fully raised when it should stop without noticeable judder.
- 'Vehicle reversing' alarm should sound while 'Tailgate raise' push-button is pressed and tailgate is rising.

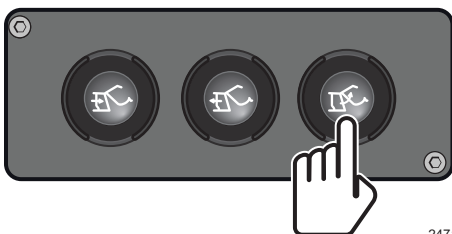
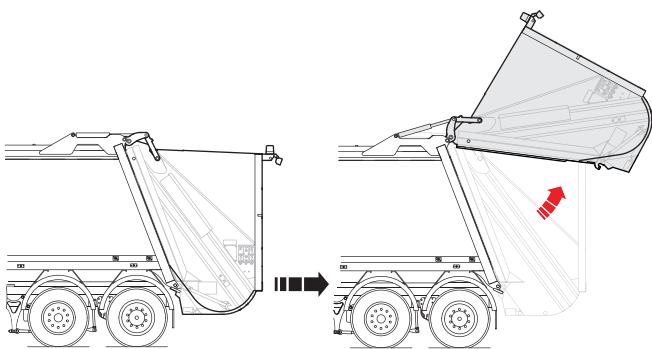

2471-OT1-D-GB-G2

85. When the tailgate is raised, the 'Tailgate fully raised' pictogram should display on the control panel screen.



2473-OT1-D-GB-G3

86. Press the 'Ejection plate eject' push-button. Release the push-button when the ejection plate has reached the end of its travel.

- Ejection plate should eject smoothly without judder.

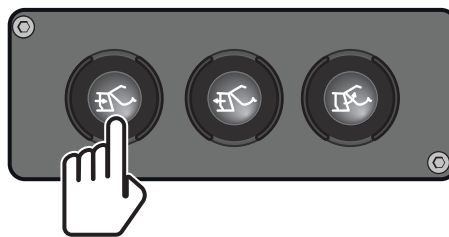
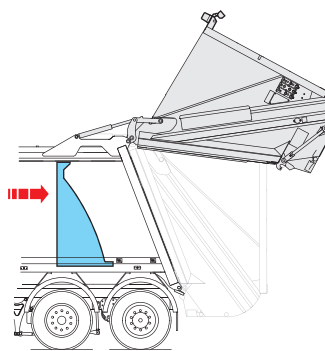

2474-OT1-D-GB-G1



87. Press the 'Ejection plate retract' push-button. Release the push-button when the ejection plate has reached the end of its travel.

- Ejection plate should retract smoothly without judder.

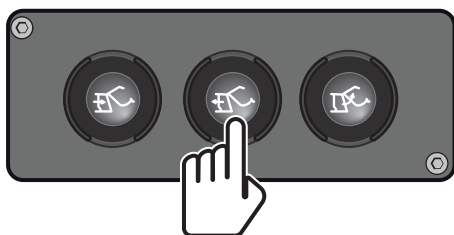
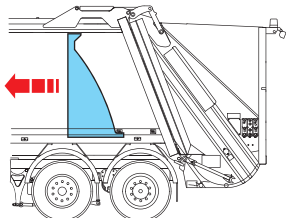

2475-OT1-D-GB-G2

88. Press the 'Ejection plate eject' push-button. Release the push-button when the ejection plate has reached the end of its travel.

- Ejection plate should eject smoothly without judder.

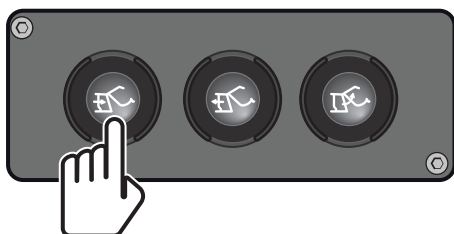
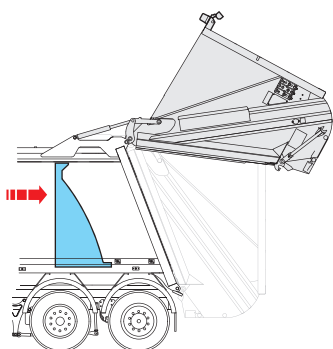

2474-OT1-D-GB-G1

89. Press the two push-buttons on the 'Tailgate lowering' control panel simultaneously until the tailgate engages locks and then release the push-buttons.

- Tailgate should rotate smoothly downwards about the hinge pins until it engages face of body, then lower into locks.

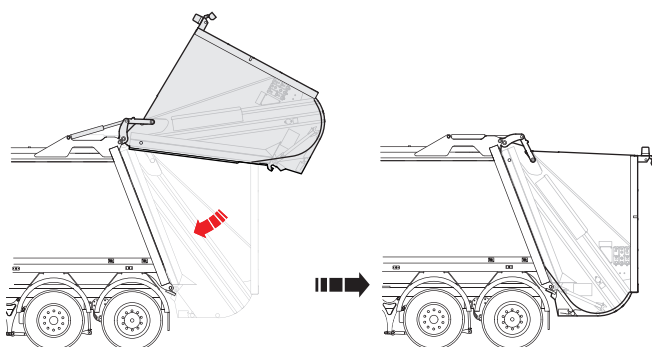

2597-OT1-D-GB-G2

- 'Vehicle reversing' alarm should sound until the tailgate engages locks when it should silence.
- The engine speed should lower to tick-over.

90. Check level of oil in hydraulic oil tank and top up if required (see '4.1 To check hydraulic system oil level' on page 4-3).



WARNING:
MAKE SURE THAT THE TAILGATE AREA IS CLEAR OF PERSONNEL.

DAILY CHECKS

3.2 Warning labels

3

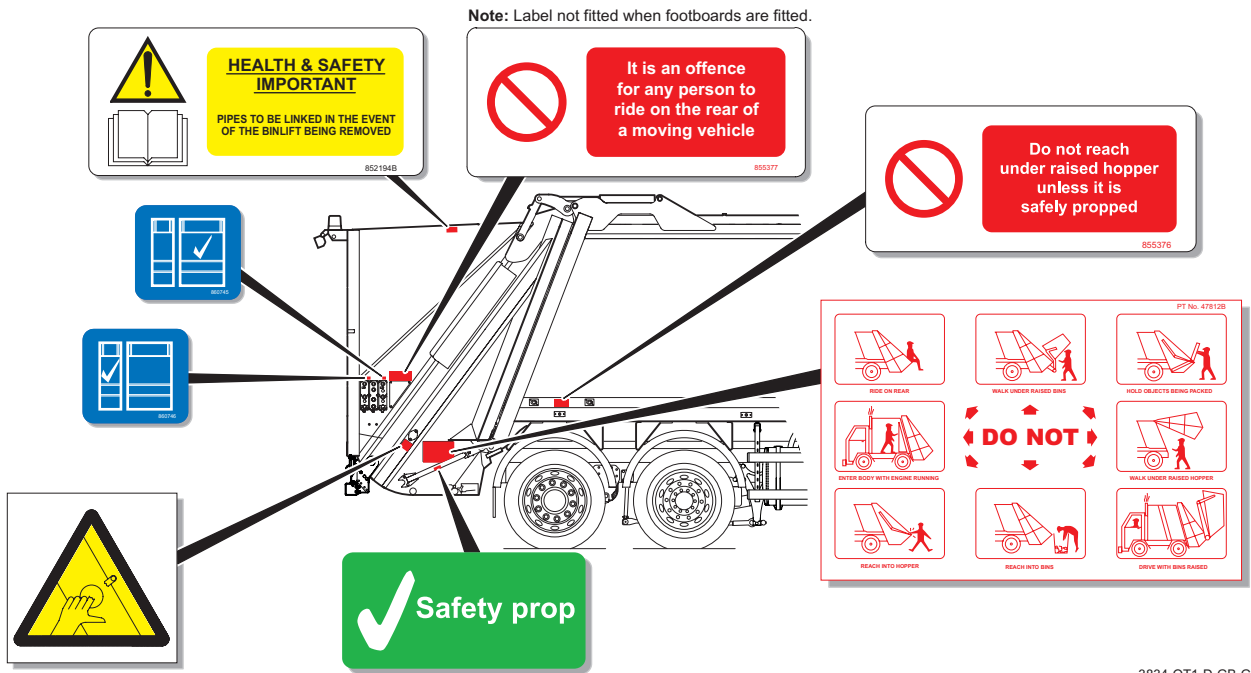

3834-OT1-D-GB-G2

Fig. 3-1 Warning labels; right-hand rear of refuse collection bodywork

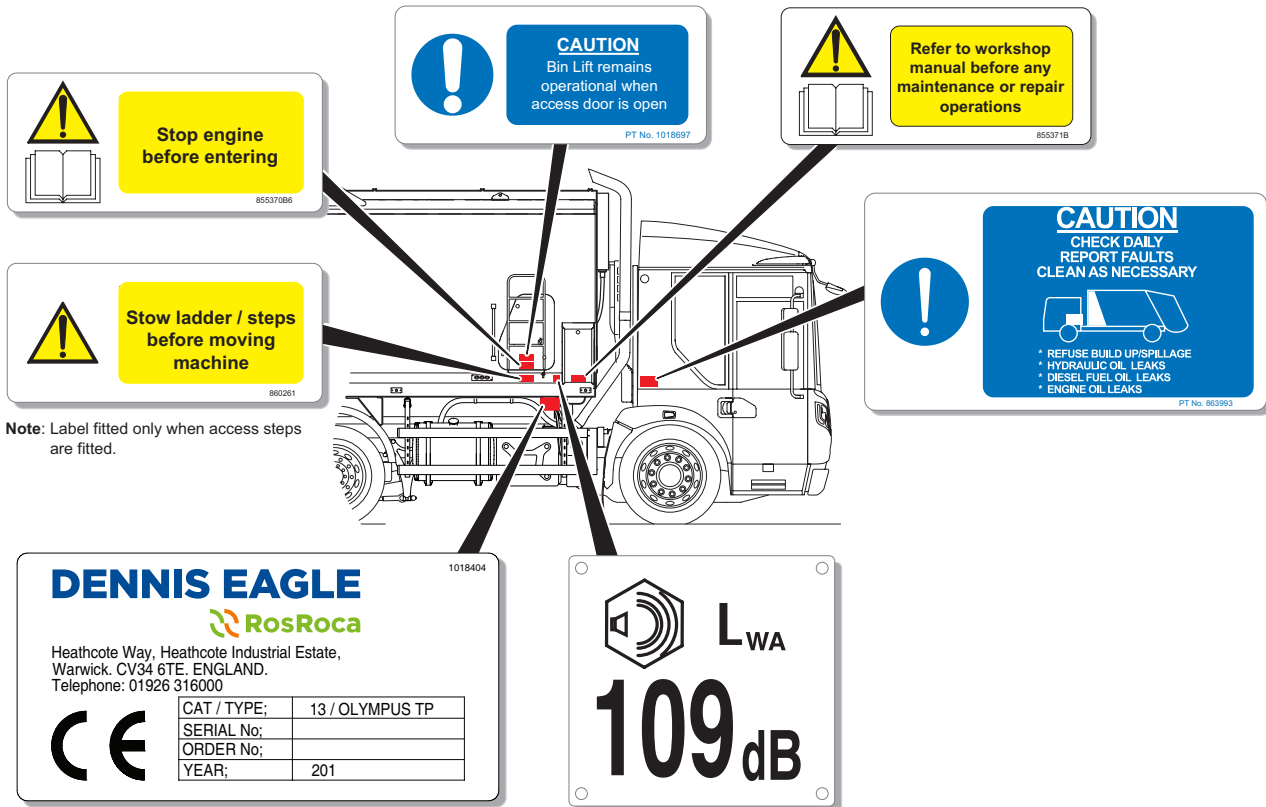

3835-OT1-D-GB-G2

Fig. 3-2 Warning labels; right-hand front of refuse collection bodywork

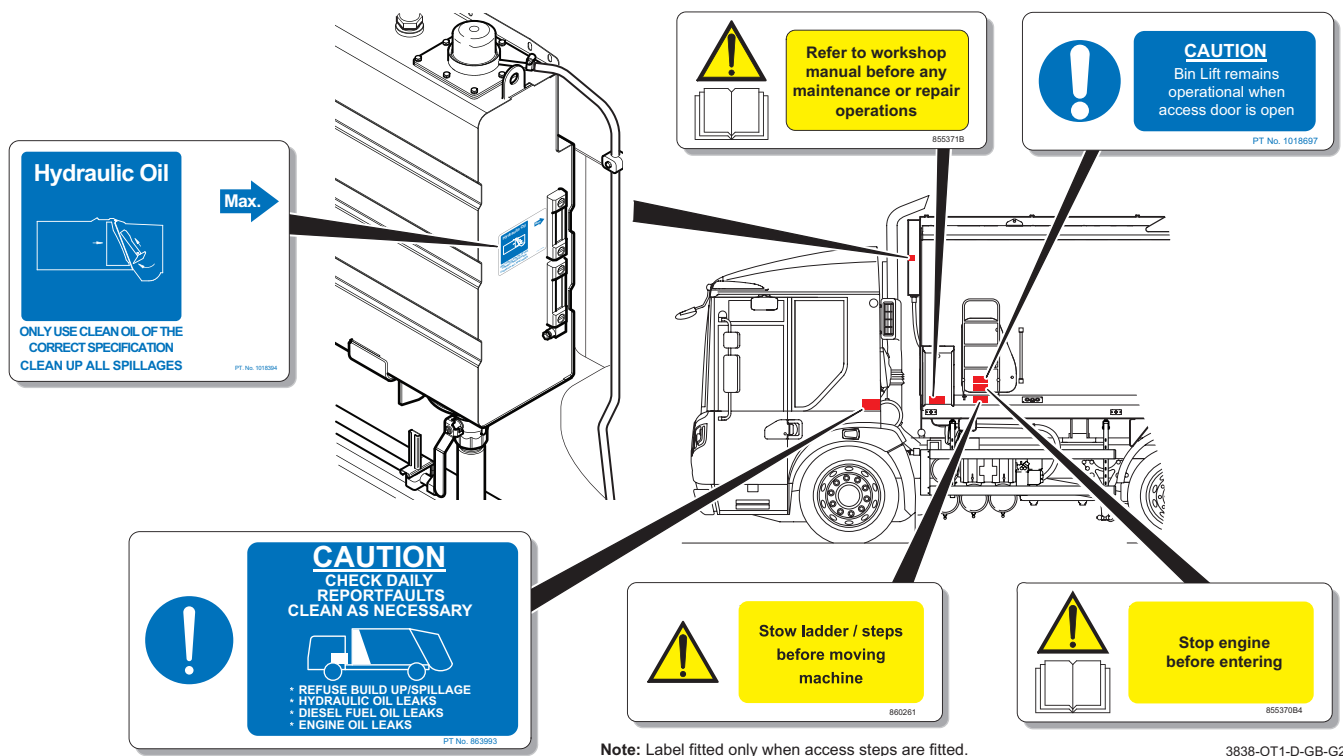

Fig. 3-3 Warning labels; left-hand front of refuse collection bodywork

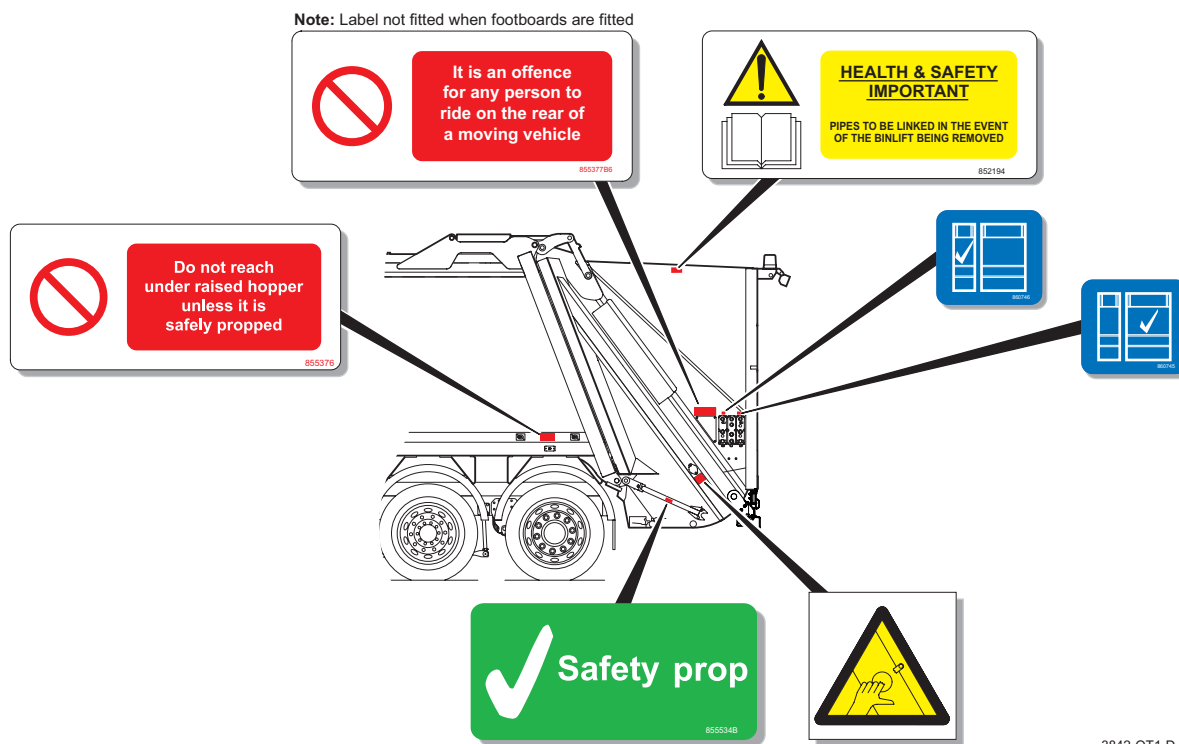
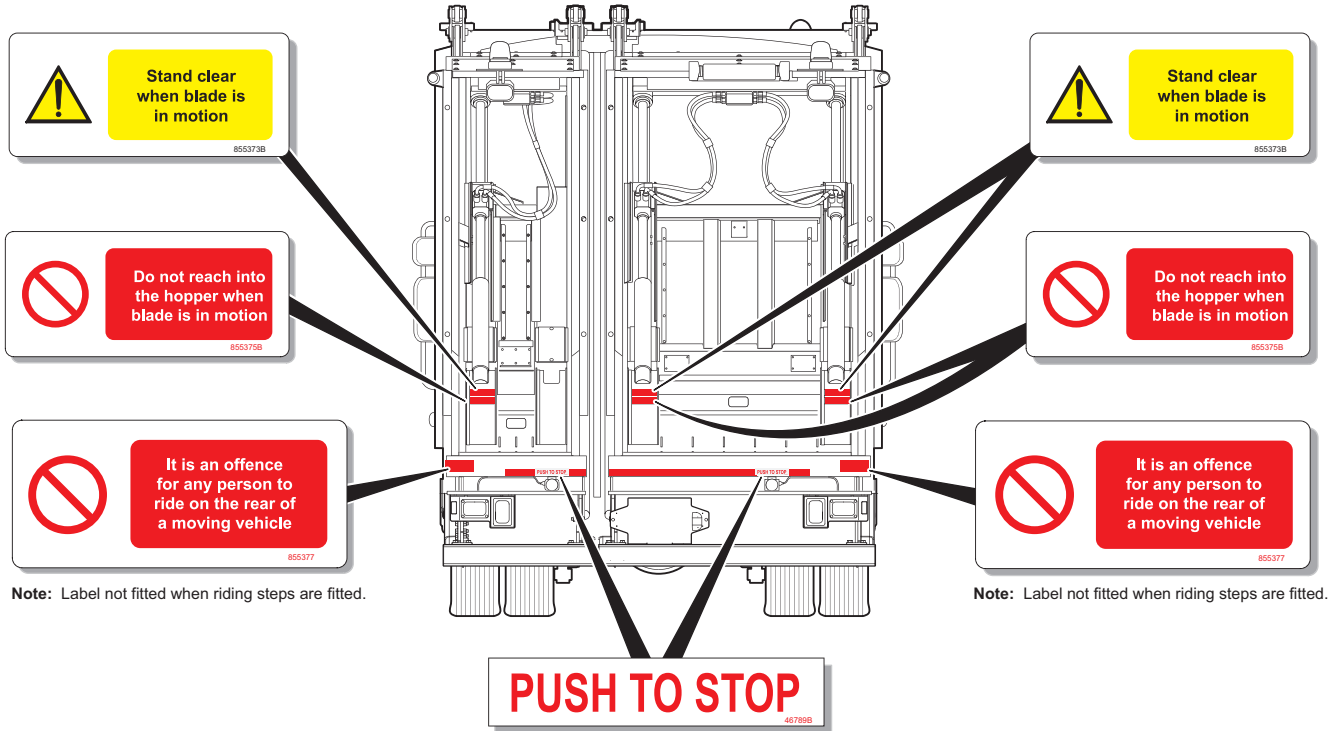
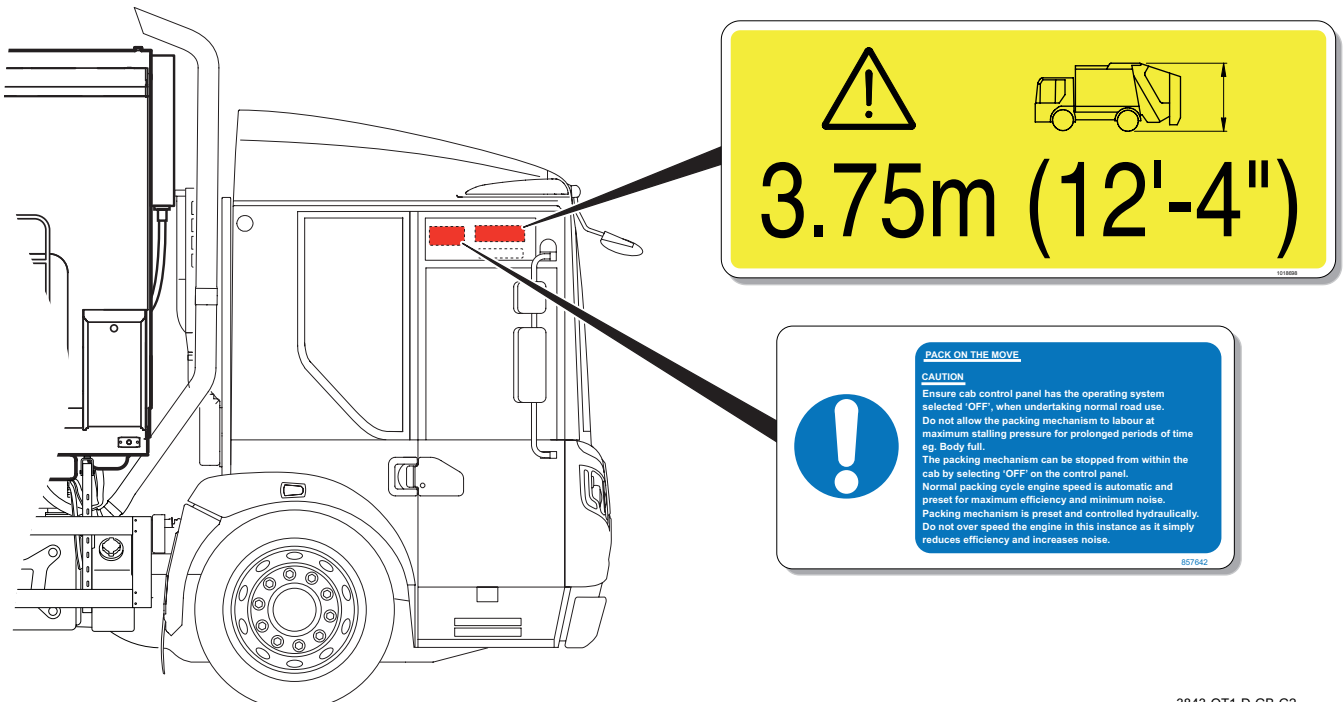

Fig. 3-4 Warning labels; left-hand rear of refuse collection bodywork



3844-OT1-D-GB-G2

Fig. 3-5 Warning labels; rear of collection bodywork



3843-OT1-D-GB-G2

Fig. 3-6 Warning labels; cab



Olympus Twin Pack Service Manual

CONTENTS		PAGE
4	Hydraulic system oil level.....	4-3
4.1	To check hydraulic system oil level	4-3
4.1.1	Topping up hydraulic oil - bulk oil supply.....	4-8
4.1.2	Topping up hydraulic oil - using hand pump.....	4-9



This page intentionally left blank



4 Hydraulic system oil level

It is most important that the level of fluid in the hydraulic reservoir is maintained within the specified limits.

Topping up of the oil must be conducted in a controlled workshop environment using a pressurised filling system connected to a quick release coupling on the system. Operator's without a bulk oil delivery system are supplied with an optional hand pump and hoses.

It is most important that the hydraulic system is maintained according to Dennis Eagle Limited Maintenance Schedule and associated instructions.

System maintenance and filter element change requirements are specified in Chapter 6 'Scheduled maintenance' of this Manual.

4.1 To check hydraulic system oil level



WARNING:
THE BODY MUST BE EMPTY WHEN CHECKING THE HYDRAULIC SYSTEM OIL LEVEL.

The level is checked with:

- Both tailgates fully lowered (cylinders open).
- Both ejection plates fully ejected to the rear of the body (cylinder open).
- Both compaction mechanism packer plates closed (cylinders open) and both carriage plates fully raised (cylinders closed).

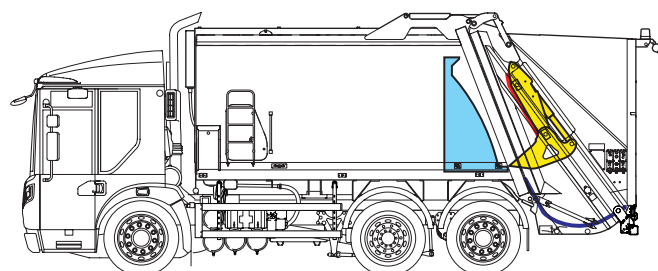

2927-OT1-D-GB-G3

This is shown on the label adjacent to the hydraulic oil level gauge.

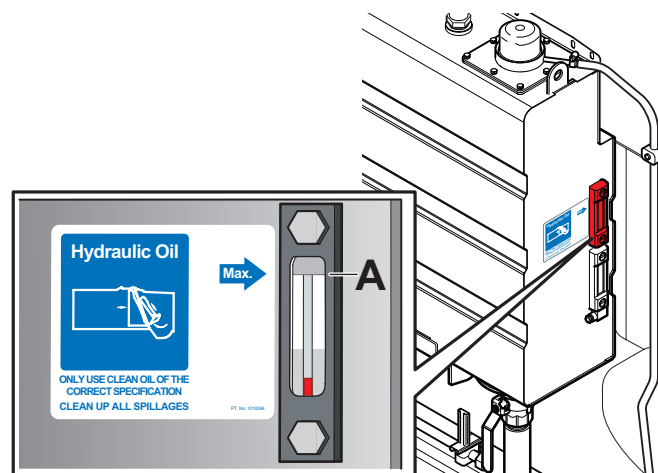

Procedure

1. Stand the vehicle on clean, level and stable ground with sufficient clearance to allow for the tailgates to be fully raised.
2. Engage the parking brakes.
3. Select Neutral 'N'.
4. Check that both tailgates are in the normal position locked to the body.
5. Make sure that all personnel are clear of the body, tailgates and rear of the vehicle.

HYDRAULIC SYSTEM OIL LEVEL



- Start and run the engine.
 - The screen will initialise and then display the 'Body system off' mode.

- The screen will display the 'Body system run' mode.

4

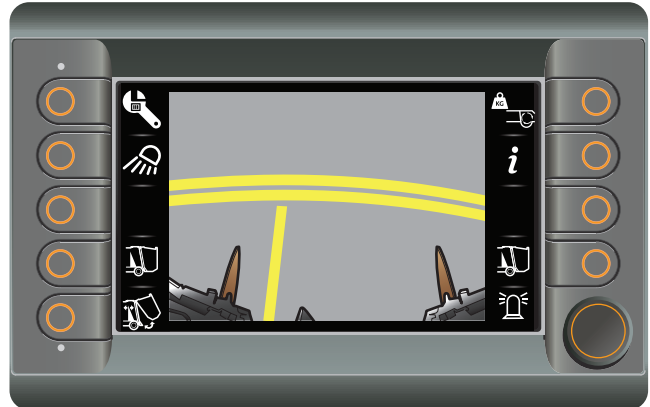

2248-OT1-D-GB-G4

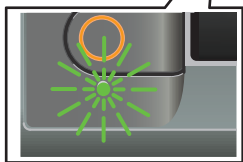

3885-OT1-D-GB-G2

If LED below the left-hand bank of switches flashes amber, turn the 'Body main' switch to off and then back to on.



2365-OT1-D-GB-G4

- Turn the 'Body main' switch on.



WARNING:
IF A WARNING PICTOGRAM DISPLAYS IN THE MESSAGE AREA OF THE SCREEN, INVESTIGATE AND RECTIFY THE CAUSE OF THE WARNING BEFORE OPERATING THE SYSTEM.



3873-OT1-D-GB-G3



HYDRAULIC SYSTEM OIL LEVEL

8. For each tailgate operate the 'Start pack cycle' push-button on the energised 'Compaction mechanism' control panel so that the compaction mechanism completes a full cycle and the packer plate is closed and carriage plate fully raised.

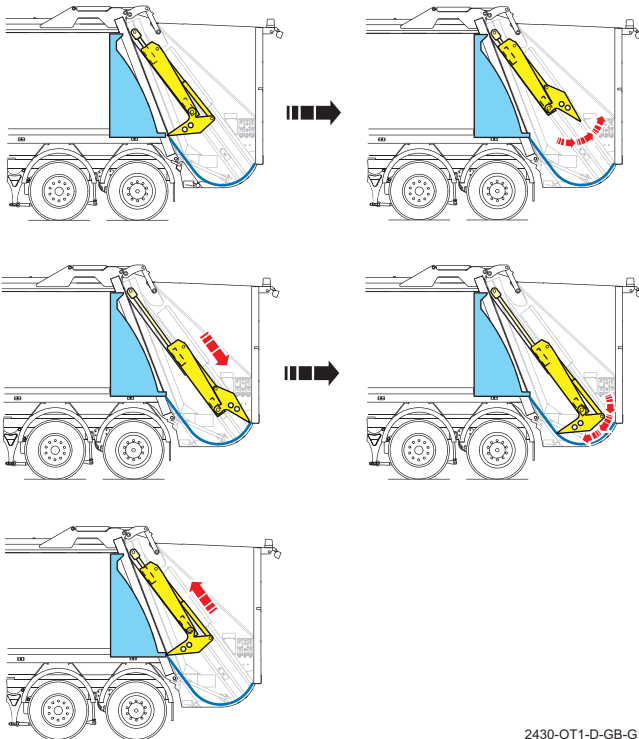
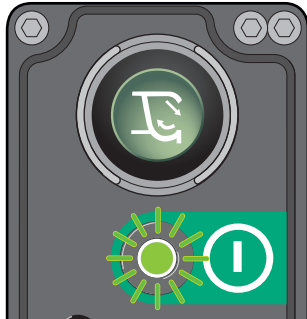

2430-OT1-D-GB-G1

9. Turn the 'Body selector' switch to select the left-hand body.

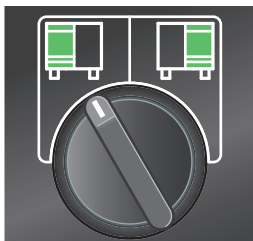

2243-OT1-D-GB-G2

10. Press and release the internal discharge switch on the cab control panel.

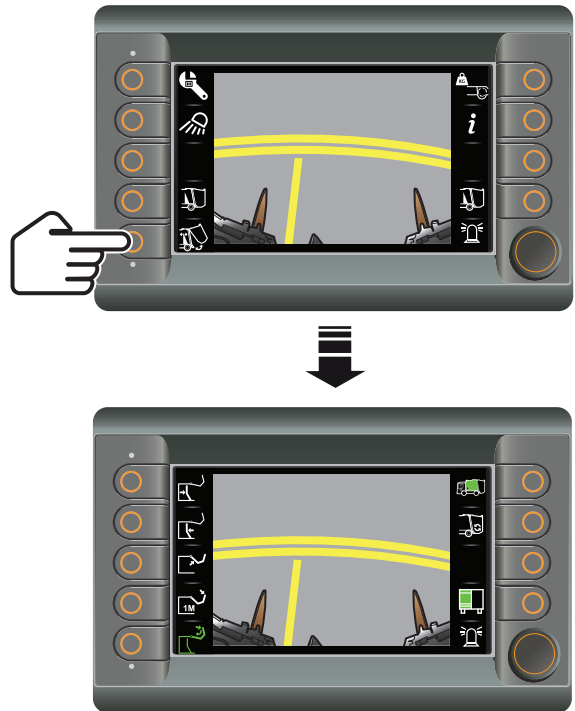

2354-OT1-D-GB-G4

- The screen will display the 'Body discharge internal controls' mode.



WARNING:
MAKE SURE THAT YOU KNOW THE HEIGHT OF YOUR VEHICLE WITH THE TAILGATE AND WASTE CONTAINER LIFTING DEVICE, IF FITTED, RAISED.

HYDRAULIC SYSTEM OIL LEVEL



11. Press and hold the tailgate raise switch until the tailgate is out of its locks and then release the switch.

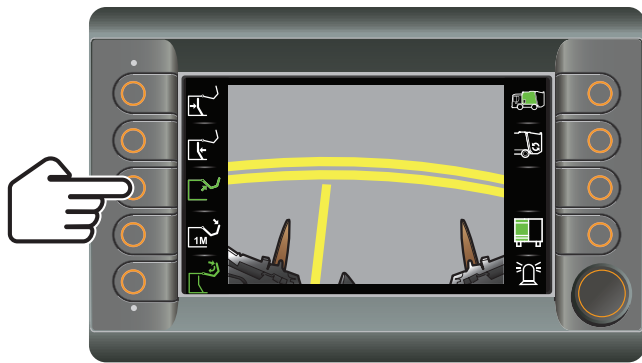

12. Press and hold the eject switch to move the ejection plate to the rear of the body. Release the switch when the ejection plate is at the rear of the body.

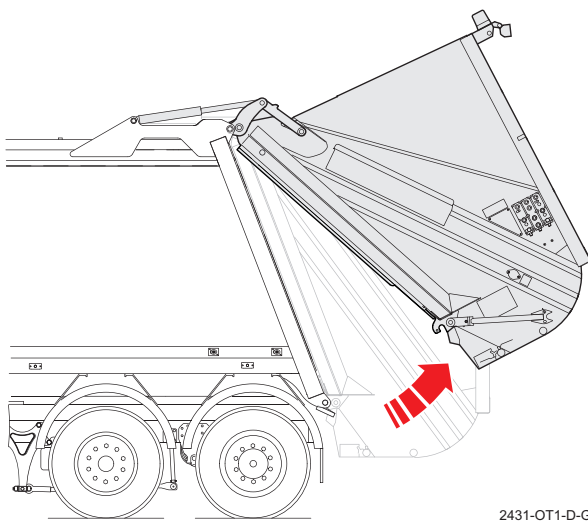
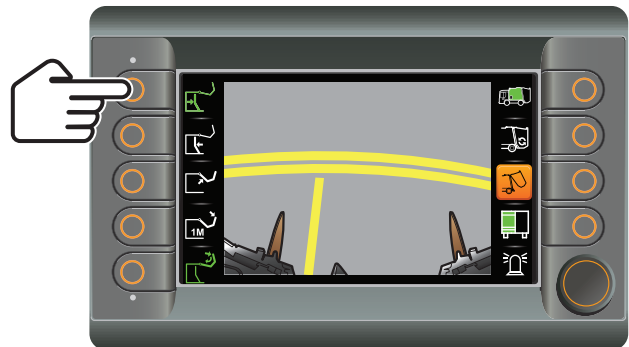

2431-OT1-D-GB-G3

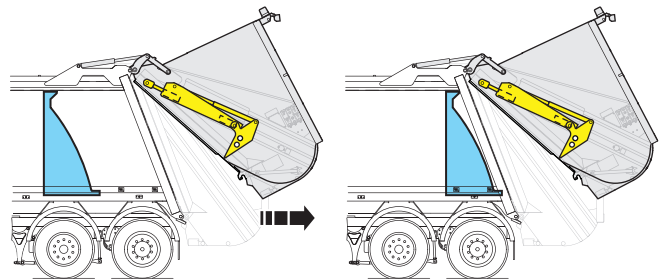

2577-OT1-D-GB-G3

13. Press the two push-buttons on the 'Tailgate lowering' control panel simultaneously to lower the tailgate fully into its locks.



2387-OT1-D-GB-G1

14. Turn the 'Body selector' switch to select the right-hand body.

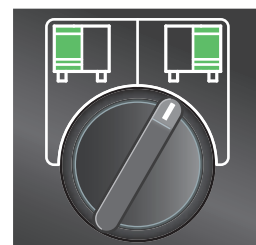

2244-OT1-D-GB-G2



HYDRAULIC SYSTEM OIL LEVEL

15. Repeat operations 11 to 13 to move the left-hand ejection plate to the rear of the body.
16. Turn the 'Body main' switch to off position. Remove and retain the key.
17. Switch ignition off. Remove and retain the key.
18. Lock all cab doors. Remove and retain the keys.
19. Check the oil level.
 - The reservoir is fitted with two oil sight glasses. The upper glass is marked with black and red lines to show maximum (see Fig. 4-1, A) and minimum (see Fig. 4-1, B) levels respectively during normal operation.
 - The level should align with the point of the arrow (see Fig. 4-1, C) on the label adjacent to the upper glass when:
 - Both tailgates fully lowered (cylinders open).
 - Both ejection plates fully ejected to the rear of the body (cylinder open).
 - Both compaction mechanism packer plates closed (cylinders open) and both carriage plates fully raised (cylinders closed).



Caution:
If the oil level is only visible in the lower sight glass, the hydraulic system must not be used until the system has been filled to the correct level.

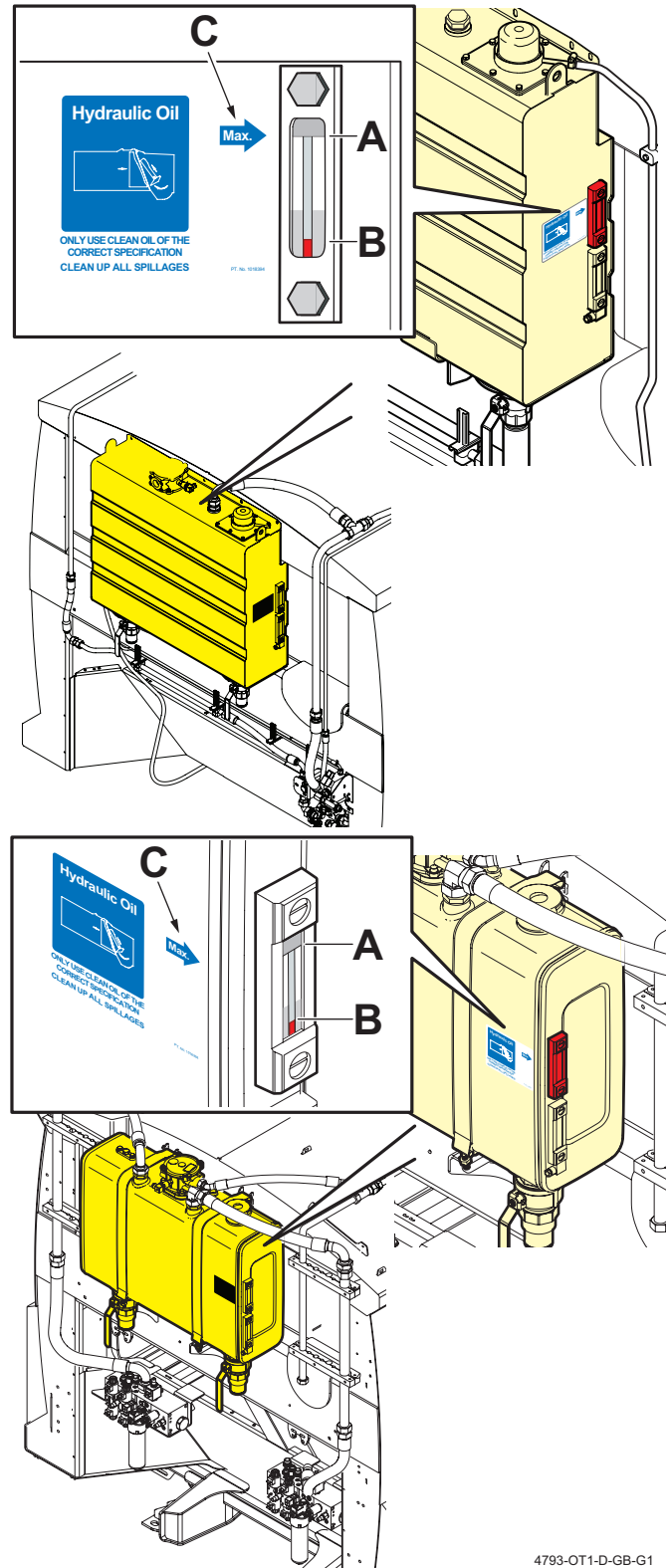

Fig. 4-1 Hydraulic oil level

4793-OT1-D-GB-G1



4.1.1 Topping up hydraulic oil - bulk oil supply

- If topping up is necessary, thoroughly clean:
 - The quick release coupling cap and its surrounding area.
 - Any filling equipment to be used.

- Connect the filling equipment to the quick release coupling (see Fig. 4-2). Top up as necessary to the correct level using new hydraulic oil to the correct specification.

Temperature range	BS 4231 Viscosity grade	ISO Oil type	Manufacturers specification
-30° to +80°	32	HM	Q8 Foil 32 Note: Q8 Foil 32 used on new equipment. Biodegradable viscosity 46 oil is used where specified by customers.



Caution:
Do not mix different oil types.

- Disconnect the filling equipment from the quick release coupling.
- Replace the quick release coupling cap.
- If the hydraulic level is very low, inspect all the hydraulic systems including waste container lifting devices, if fitted, for hydraulic oil leaks. Rectify any leaks before operating the vehicle.

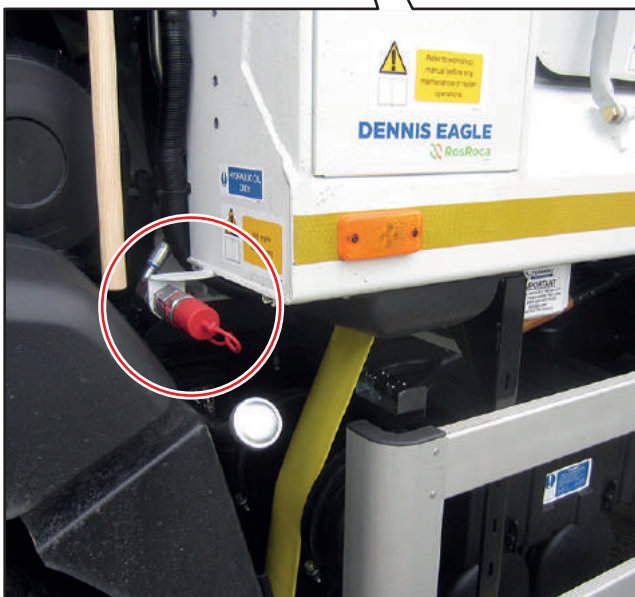
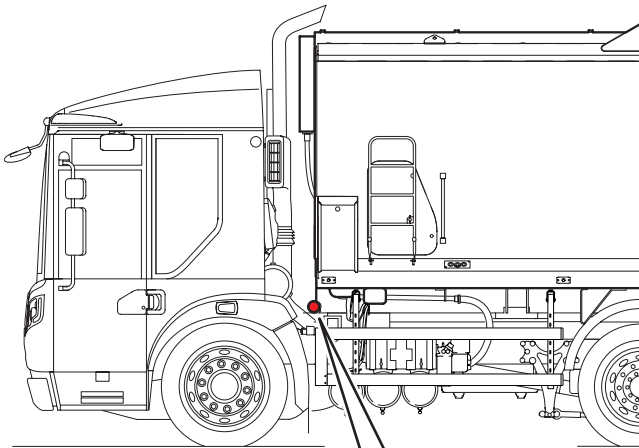

2434-OT1-D-GB-G4

Fig. 4-2 Quick release coupling



4.1.2 Topping up hydraulic oil - using hand pump

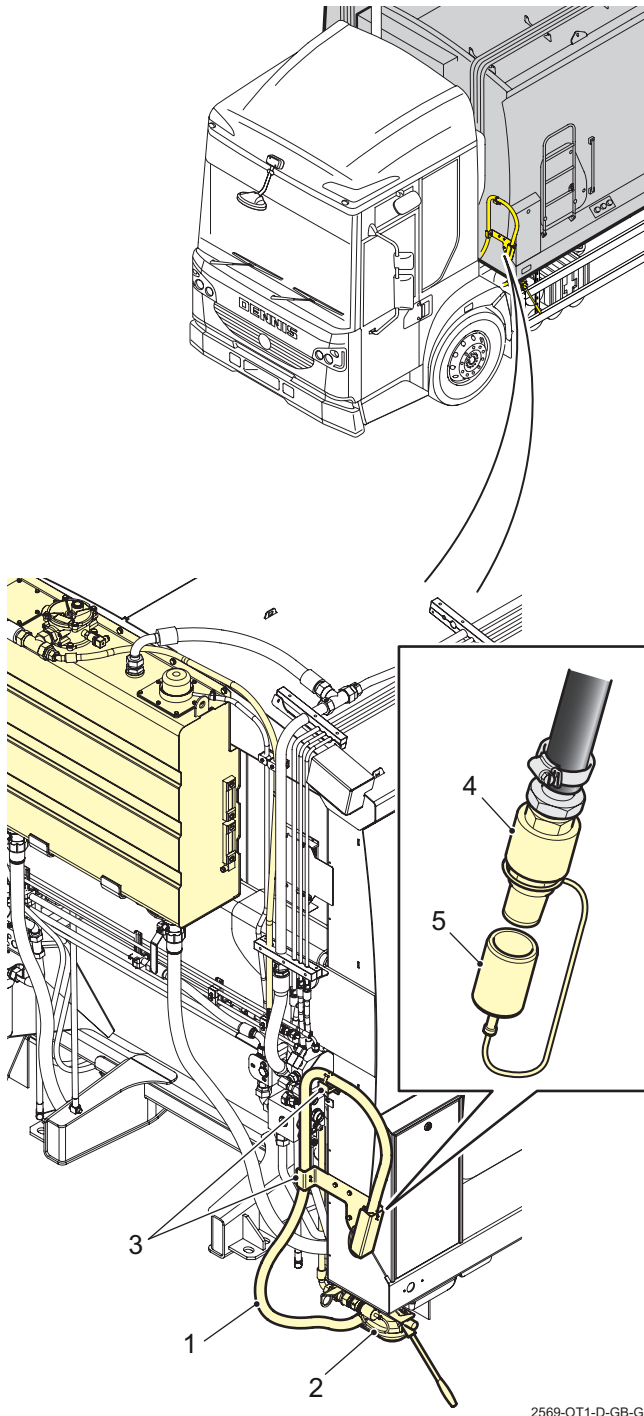

2569-OT1-D-GB-G3

Fig. 4-3 Hand pump

1. Filler hose.
2. Pump.
3. Filler hose securing clips.
4. Inlet filter.
5. Protective cap.

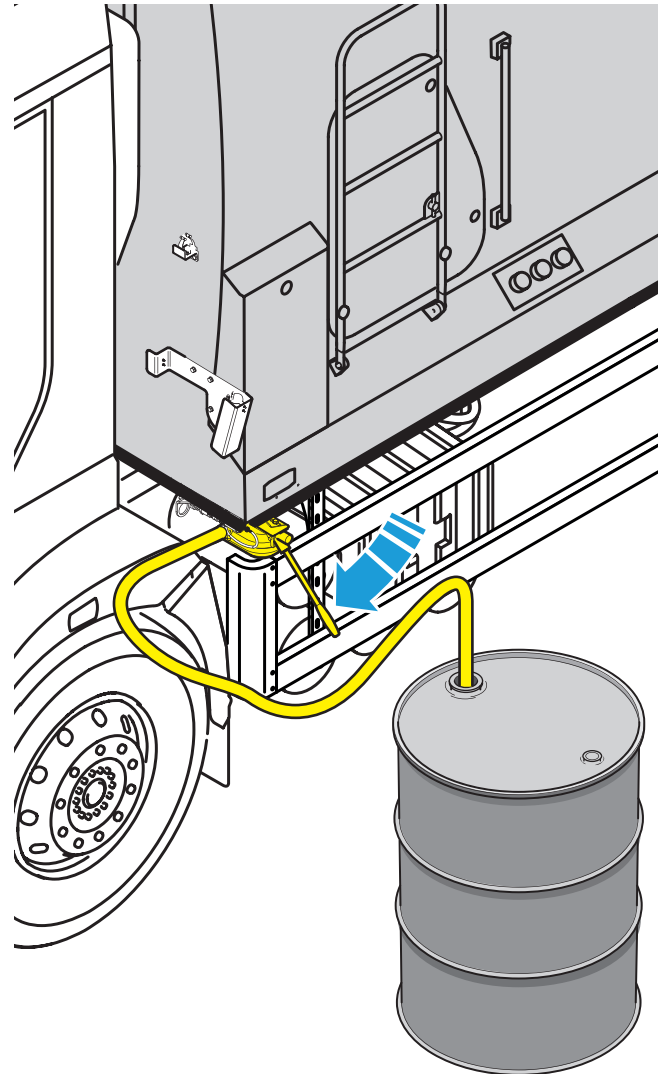

2570-OT1-D-GB-G3

Fig. 4-4 Hand pump connections

1. Position a drum of new hydraulic oil close to the filler point.
2. Clean the top of the drum and unscrew the filler plug.
3. Release the filler hose from its mounting clips and unstow the hose.
4. Clean the filler hose.
5. Withdraw the protective cap from the inlet filter.
6. Insert the filler hose into the oil drum, so that the filter is submerged in the oil.
7. Insert the handle into the pump.
8. Operate the pump until the oil level in the tank is correct.
9. Withdraw the filler hose from the drum and wipe clean. Refit the protective cap over the filter and stow the hose securely in its mounting clips.
10. Refit the filler plug in the drum and remove the oil drum.



This page intentionally left blank



Olympus Twin Pack Service Manual

CONTENTS		PAGE
5	Cleaning	5-3
5.1	Drain	5-4
5.1.1	Body drain.....	5-4
5.1.2	Tailgate drains.....	5-4
5.2	Daily cleaning	5-5
5.3	Pressure washing.....	5-6
5.4	Cleaning the leachate tank.....	5-6



This page intentionally left blank



5 Cleaning

The refuse collection vehicle and its ancillary equipment must be kept as clean as possible to prevent potential health hazards and promote trouble free operation.

The vehicle may be cleaned using proprietary detergent solutions for cleaning commercial vehicles and steam cleaning according to the following guidelines.



Caution:
Caustic or acidic cleaning solutions must not be used as they may damage components and assemblies. Use of such solutions may invalidate the warranty granted with this product.



WARNINGS:
NEVER ENTER A TAILGATE OR BODY TO CLEAN DEBRIS UNLESS:

- YOU KNOW AND CAN WORK TO THE SAFE WORKING PROCEDURES DETAILED IN THE SERVICE MANUAL.
- THE BODY MAIN SWITCH IS IN THE OFF POSITION WITH THE KEY REMOVED.
- THE IGNITION IS IN THE OFF POSITION WITH THE KEY REMOVED.
- A SIGN READING 'DO NOT START OR OPERATE VEHICLE' IS SECURED TO THE STEERING WHEEL.
- ALL CAB DOORS ARE LOCKED WITH THE KEYS REMOVED.
- YOU ARE IN POSSESSION OF ALL THE KEYS, AND ANY SPARE KEYS.

WEAR PROTECTIVE CLOTHING, GLOVES AND GOGGLES WHEN CLEANING. LOOSE DEBRIS MAY BE EJECTED FROM THE BODY AND TAILGATE.

THE VEHICLE IS FITTED WITH BODY/ TAILGATE SEALS, WHICH MINIMISE FLUID LOSS WHEN COLLECTING VERY WET REFUSE. IT IS IMPORTANT EACH SEAL AND ITS MATING FACE ARE KEPT CLEAN. CLEANING SHOULD TAKE PLACE AFTER THE DISCHARGE OPERATION.

REPORT ANY SEAL DAMAGE TO SUPERVISION IMMEDIATELY.

WHEN CLEANING A TAILGATE AND BODY BE AWARE OF DANGEROUS REFUSE SUCH AS GLASS AND HYPODERMIC NEEDLES.

NEVER CLEAN THE SEAL AREA UNLESS THE TAILGATE IS FULLY PROPPED.

FIRE HAZARD.
REFUSE PUSH OVER AT FRONT OF BODY DUE TO EXCESS BUILD UP OF REFUSE CAN FALL ONTO HOT ENGINE AND EXHAUST.

INSPECT THE VEHICLE DAILY TO MAKE SURE THERE IS NO REFUSE, PAPER OR FLAMMABLE MATERIALS NEAR THE ENGINE OR EXHAUST. THESE COULD CAUSE A FIRE WHEN THE ENGINE IS STARTED. IF NECESSARY, TILT THE CAB (SEE CHASSIS-CAB MANUFACTURER'S OPERATOR'S HANDBOOK) TO MAKE A THOROUGH INSPECTION.

FIRE HAZARD.
OIL SPILLAGE AT FRONT OF BODY COULD BE IGNITED BY HOT ENGINE AND EXHAUST. CLEAN UP ANY SPILLAGE AND ENSURE THAT LEAKS ARE RECTIFIED IMMEDIATELY.



Caution:
High pressure water jets can seriously damage electrical equipment. A minimum distance of one metre must be maintained when pressure washing.



5.1 Drain

5.1.1 Body drain

A body drain is at the front of each body.

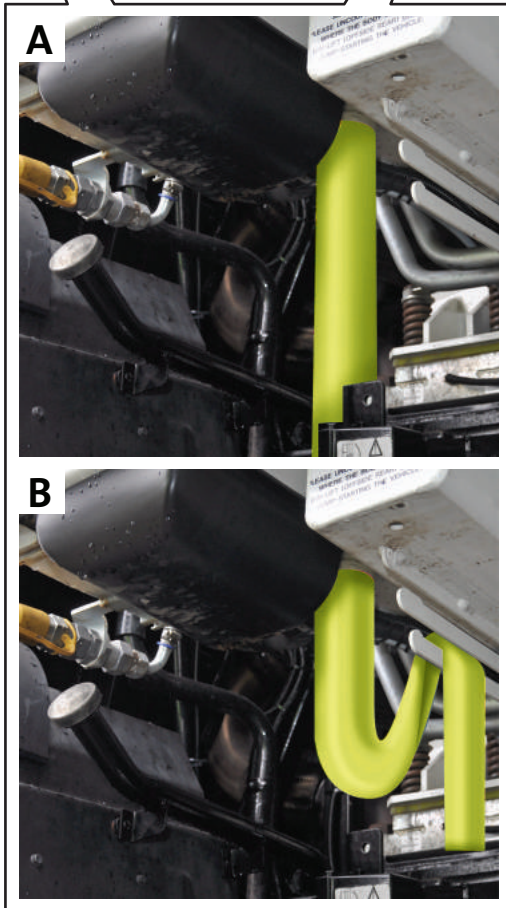
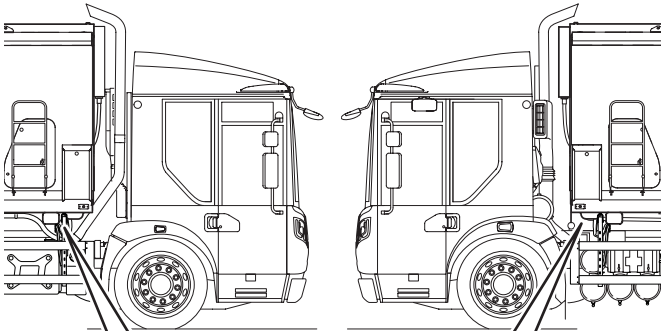

2571-OT1-D-GB-G3

Fig. 5-1 Body drain

- A. To open: Release hose.
- B. To close: Stow hose in bracket.

5.1.2 Tailgate drains

There is a drain point on the outer side of each tailgate and leachate tank (if fitted).

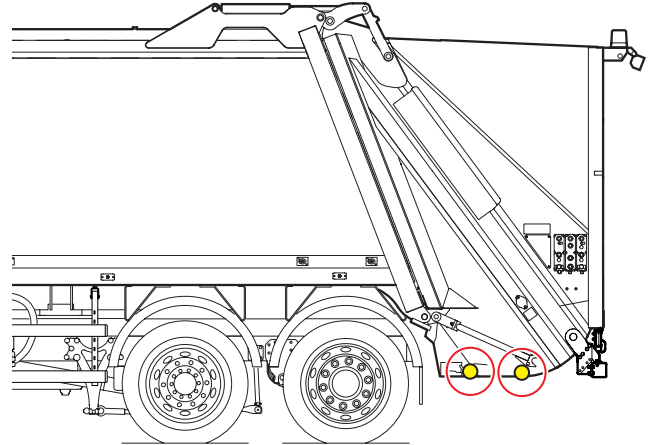

2572-OT1-D-GB-G3

Fig. 5-2 Tailgate drains

1 Plug type

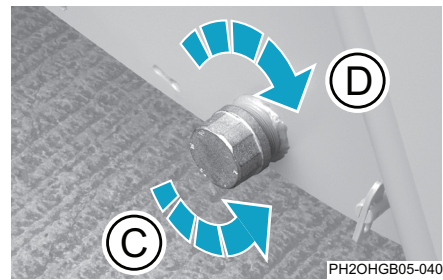

PH2OHGB05-040

- C. To open: Unscrew drain plug off drain.
- D. To close: Screw drain plug onto drain.

2 Valve type

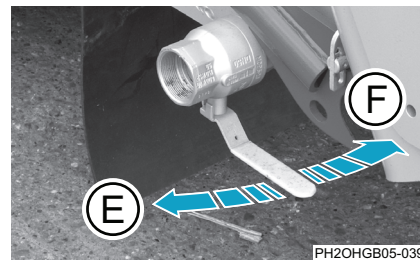

PH2OHGB05-039

- E. To open: Turn lever outwards.
- F. To close: Turn lever inwards.



5.2 Daily cleaning

1. Stand the vehicle on clean, level and stable ground with sufficient clearance to allow for the tailgates to be fully raised.
2. Engage the parking brakes.
3. Select Neutral 'N'.
4. Turn the 'Body main' switch to the off position. Remove and retain the key.



5. Switch ignition off. Remove and retain the key.
6. Secure a sign 'DO NOT START or OPERATE VEHICLE' to the steering wheel.
7. Lock all cab doors. Remove and retain the keys.
8. Inspect each tailgate hopper and remove any refuse.
9. Open the tailgate drains (see '5.1.2 Tailgate drains' on page 5-4).
10. Open the body drains (see '5.1.1 Body drain' on page 5-4).
11. Lower the access ladder (1) (if fitted) on each side of vehicle.

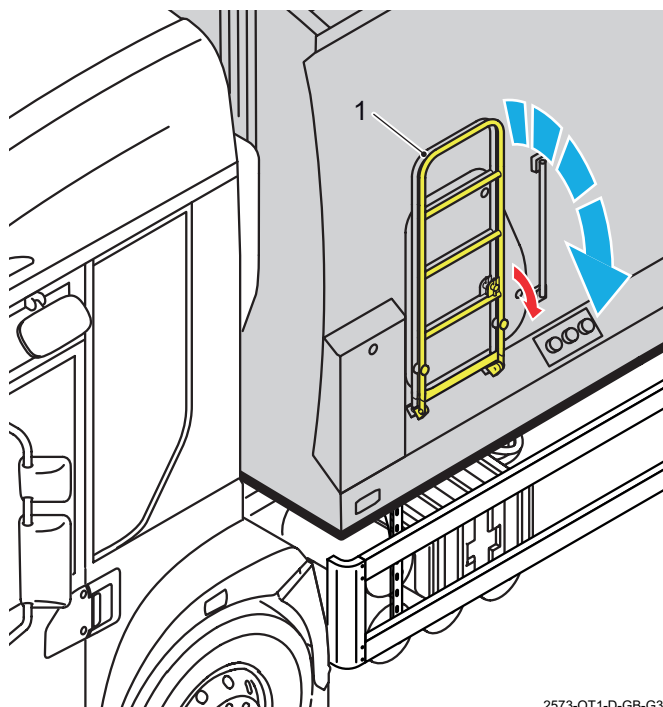

2573-OT1-D-GB-G3

12. Open each body access door.
 - Each door has a safety interlock to stop operation of the body mechanism when it is open.
13. Clean out any refuse which has entered the body in front of the ejection plate.
14. Clean debris from the body sump and wash out thoroughly. Drain through the external hose to ensure thorough cleaning is achieved.
15. Close and lock the body access doors.
16. Securely stow the access ladders (if fitted).
17. Close the tailgate drains (see '5.1.2 Tailgate drains' on page 5-4).
18. Close the body drain (see '5.1.1 Body drain' on page 5-4).
19. Make sure that there is no refuse, paper or flammable materials near the engine or exhaust. These could cause a fire when the engine is started. If necessary, tilt the cab (See Chassis-cab Manufacturer's Operator's Handbook) to make a thorough inspection.



5.3 Pressure washing



Caution:
When pressure washing the Refuse Collection Vehicle, its chassis-cab, body, refuse compaction mechanism and any ancillary equipment, such as waste container lifting devices, do not allow the jet nozzle to approach closer than 1 metre.

Clean the compaction mechanism and slide tracks by pressure washing at least once a week as follows:

1. Stand the vehicle on clean, level and stable ground with sufficient clearance to allow for the tailgate to be fully raised.
2. Engage the parking brakes.
3. Select Neutral 'N'.
4. Open the tailgate drains (see '5.1.2 Tailgate drains' on page 5-4).
5. Prop both tailgates (see 'Operator's Handbook').
6. Turn the 'Body main' switch to the off position. Remove and retain the key.



7. Switch ignition off. Remove and retain the key.
8. Secure a sign 'DO NOT START or OPERATE VEHICLE' to the steering wheel.
9. Lock all cab doors. Remove and retain the keys.
10. Using a proprietary pressure washer, clean both compaction mechanisms and ejection plates and their slide blocks and tracks.
11. Inspect both seals and their mating faces.
12. Unprop both tailgates (see 'Operator's Handbook').
13. Close the tailgate drains (see '5.1.2 Tailgate drains' on page 5-4).

5.4 Cleaning the leachate tank

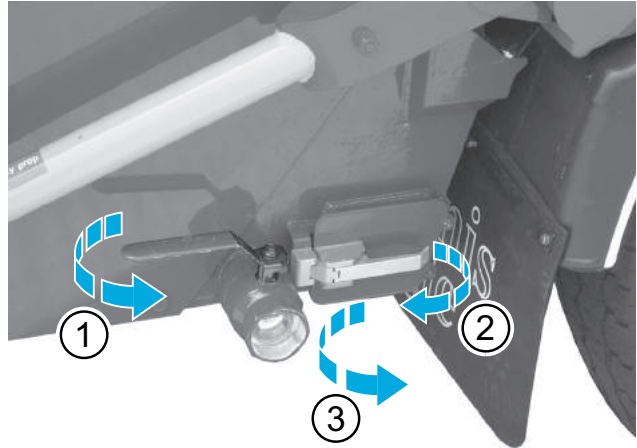

PH2OHGB01-117

Fig. 5-3 Leachate tank

1. Open ball valve drain.
2. Release leachate tank door catch.
3. Open leachate tank door.
4. Using proprietary pressure washer thoroughly clean the inside of the leachate tank.
5. Ensure all liquid has drained from the leachate tank.
6. Close the leachate tank door.
7. Close ball valve drain.



Olympus Twin Pack Service Manual

CONTENTS	PAGE
6 Scheduled maintenance	6-3
6.1 Introduction.....	6-3
6.2 Operational maintenance.....	6-3
6.3 Routine maintenance.....	6-3
6.4 Warnings.....	6-3
6.5 Maintenance summary	6-4
6.6 Lubrication.....	6-5
6.7 Weekly service checks	6-7
6.7.1 Clean the body and tailgate.....	6-7
6.7.2 Lubricate hinges and linkages.....	6-7
6.8 6-Week service checks	6-8
6.8.1 Check the security of body mounting bolts.....	6-8
6.8.2 Clean the tailgate proximity switches.....	6-10
6.9 12-Week service checks	6-11
6.9.1 Body checks.....	6-11
6.9.2 Tailgate checks.....	6-11
6.9.3 Hydraulic system components checks.....	6-12
6.9.4 Electrical system checks	6-12
6.9.5 Power Take-Off propeller shaft (if fitted)	6-12
6.9.6 Hand wash unit (optional item).....	6-13
6.9.7 Operational check.....	6-13
6.9.8 Compaction mechanism cycle time check.....	6-13
6.9.9 Tailgate lower time check	6-13
6.10 12-Month service checks.....	6-14
6.10.1 Renew hydraulic oil filter elements.....	6-14
6.11 24-Month hydraulic system oil quality check/ 36-month hydraulic system oil change.....	6-16



This page intentionally left blank



6 Scheduled maintenance

6.1 Introduction

The refuse collection mechanism should be serviced only by skilled engineers who have received the approved Dennis Eagle Ltd. training and who are fully conversant with its operation and safety procedures.

6.2 Operational maintenance

It is important that your machine is kept in good working order. Before the vehicle is put into service, carry out the inspection procedure 'Daily safety checks' as specified in Chapter 3 'Daily checks' of this Manual to confirm the correct operation of the machine, its controls, safety circuits and interlocks.

Make sure that there is no mechanical damage or wear evident in the refuse mechanism especially in the pivoting and locking of the tailgate to the body.

Any problems must be reported to supervision immediately.

6.3 Routine maintenance

To maintain the mechanism at peak operational efficiency and good condition:

- The refuse collection mechanism should be serviced according to the procedures and at the intervals specified in this chapter.
- Only approved lubricants, fluids and replacement parts must be used when servicing the vehicle as specified in Chapter 8 'General specification data' of this Manual.

6.4 Warnings



WARNINGS:
DO NOT WALK ON THE BODY ROOF OR TAILGATE TOP COVER PANELS.

IT IS THE RESPONSIBILITY OF THE TECHNICIAN TO COMPLY WITH ALL THE RELEVANT SAFETY PRECAUTIONS AND PROCEDURES LISTED IN CHAPTER 2 'HEALTH AND SAFETY' OF THIS MANUAL AS WELL AS ALL PREVAILING SAFE SYSTEMS OF WORK, HEALTH AND SAFETY REGULATIONS, WORKSHOP REGULATIONS AND WORKSHOP CODES OF PRACTICE WHEN CARRYING OUT THE PROCEDURES DESCRIBED IN THIS MANUAL.

SCHEDULED MAINTENANCE



6.5 Maintenance summary

Operation	Reference	Interval						
		Every Day	Every Week	Every 6 Weeks	Every 12 Weeks	Every Year	Every 2 Years	Every 3 Years
Clean body and tailgate.	Page 5-5	X	X	X	X	X	X	X
Daily safety check.	Page 3-3	X	X	X	X	X	X	X
Check warning labels.	Page 3-28	X	X	X	X	X	X	X
Check hydraulic system oil level.	Page 4-3	X	X	X	X	X	X	X
Pressure wash compaction mechanism and slide tracks.	Page 5-6		X	X	X	X	X	X
Lubricate hinges and linkages	Page 6-5		X	X	X	X	X	X
Check security of body mounting bolts	Page 6-8			X	X	X	X	X
Clean tailgate proximity switches	Page 6-10			X	X	X	X	X
Check condition, integrity and security of body components	Page 6-11				X	X	X	X
Check condition, integrity and security of tailgate components	Page 6-11				X	X	X	X
Check condition, integrity and security of hydraulic system components	Page 6-12				X	X	X	X
Check condition, integrity and security of electrical system components	Page 6-12				X	X	X	X
Check condition, integrity and security of Power Take-Off	Page 6-12				X	X	X	X
Check condition, integrity and security and operation of handwash unit	Page 6-13				X	X	X	X
Check compaction mechanism cycle time	Page 6-13				X	X	X	X
Check tailgate lower time	Page 6-13				X	X	X	X
Renew hydraulic oil filter elements	Page 6-14					X	X	X
Check condition of hydraulic oil	Page 6-16						X	
Renew hydraulic oil strainer filters	Page 6-16							X
Renew hydraulic oil	Page 6-16							X



6.6 Lubrication

1. Immobilise the vehicle (see '1.2 Immobilising the vehicle prior to service procedures' on page 1-3).
2. Clean the following mechanisms and lubricate with clean oil:
 - Access door hinges (see Fig. 6-1, 1 & Fig. 6-2, 1).
 - Access door budget locks (see Fig. 6-1, 2 & Fig. 6-2, 2).



WARNING:
THE POWER TAKE OFF EXPOSED SHAFT AND GREASE NIPPLE ROTATE WHEN THE ENGINE IS RUNNING.

3. Clean the following mechanisms and lubricate with grease:
 - Power Take-Off (1 nipple; Use Spline Lubricant Chelsea Part No. 379688 or Castrol Optimol Paste White 'T' for this grease nipple) (see Fig. 6-1, 3).
 - Power Take-Off propeller shaft (3 nipples, when fitted) (see Fig. 6-1, 4).
 - Carriage plate/Packer plate bearings (4 nipples per wide packer plate, 2 nipples per narrow packer plate) (see Fig. 6-2, 5).
 - Packer plate cylinder bearings (2 nipples per cylinder) (see Fig. 6-2, 6).
 - Tailgate hinges (see Fig. 6-2, 7).

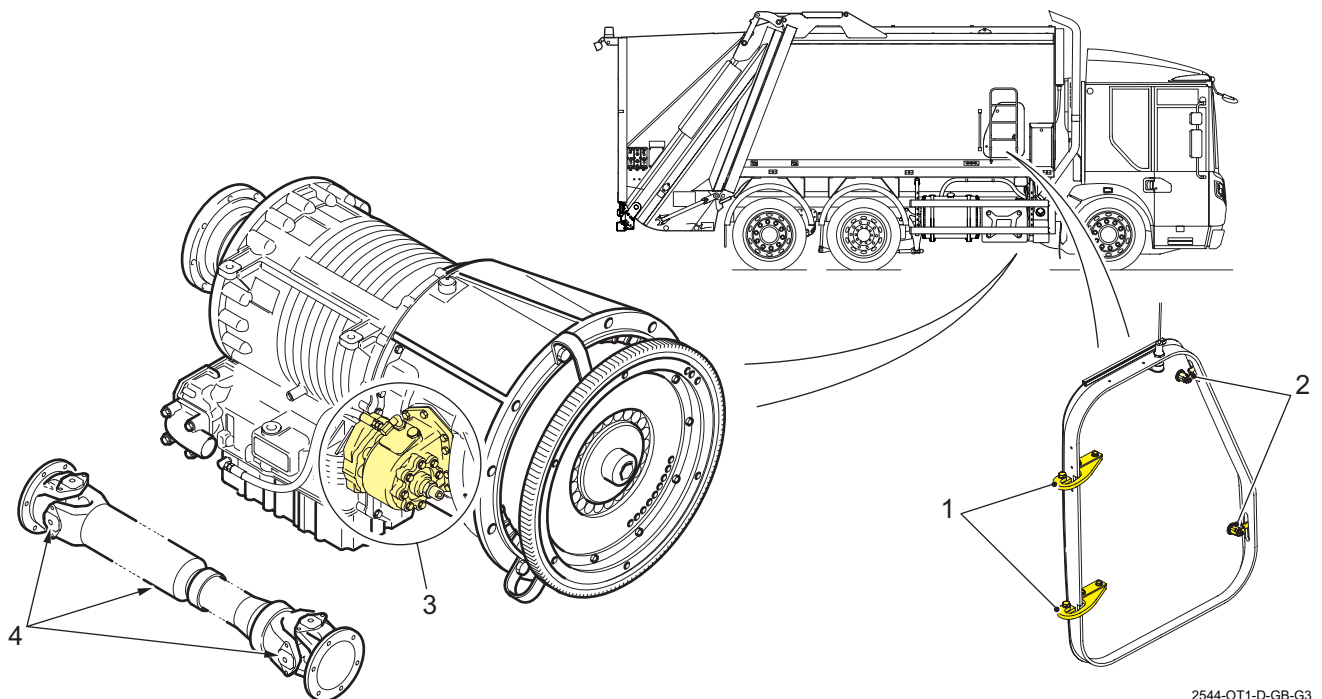

Fig. 6-1 Lubrication points



6

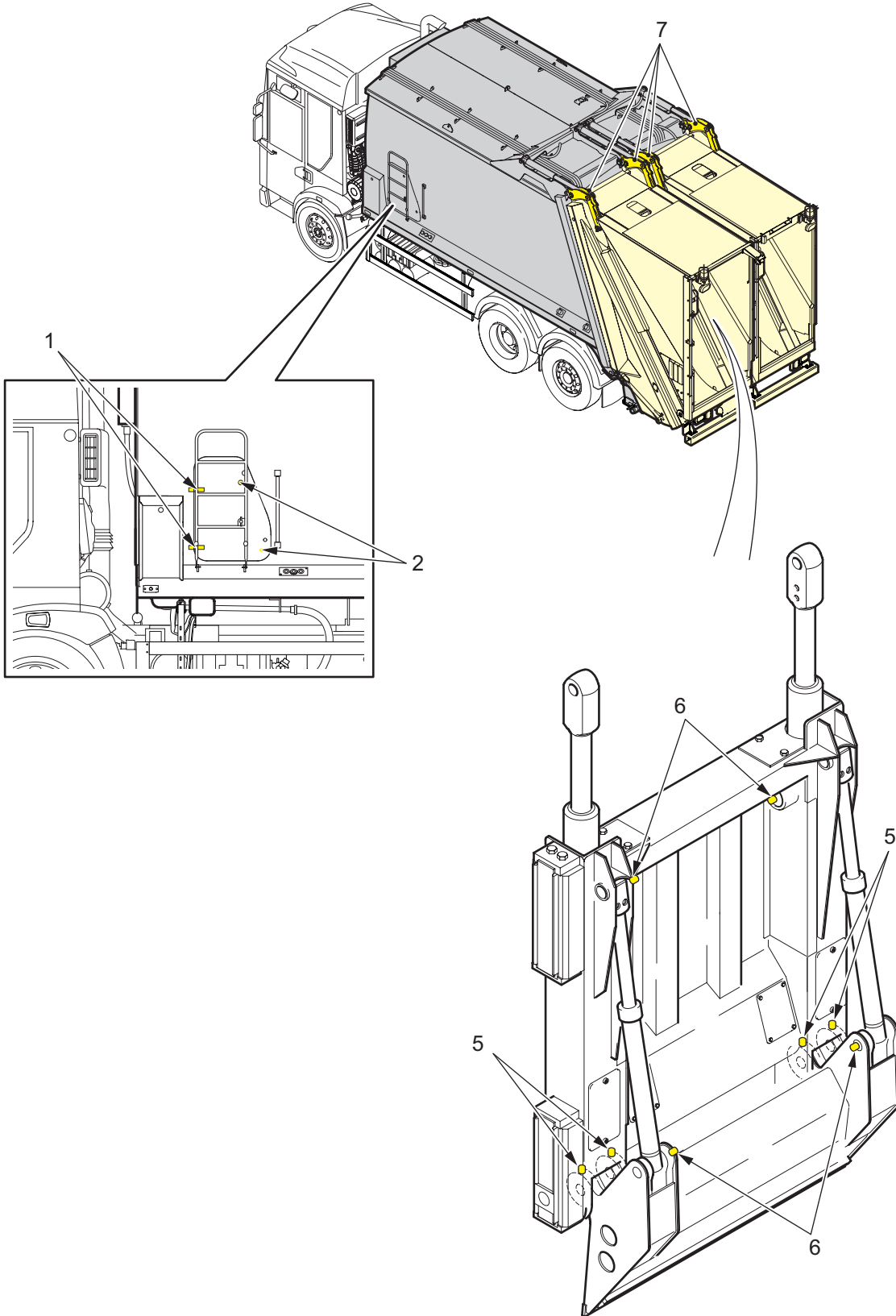

Fig. 6-2 Lubrication points

2547-OT1-D-GB-G3



6.7 Weekly service checks

The following service checks should be carried out once a week or more frequently when the Refuse Collection Vehicle is operating in severe conditions.

The following service checks should be carried out in addition to the Daily Service Checks.

6.7.1 Clean the body and tailgate

(See Fig. 6-3).

1. Immobilise the vehicle (see '1.2 Immobilising the vehicle prior to service procedures' on page 1-3).
2. Clean each tailgate using a pressure washer (see '5.3 Pressure washing' on page 5-6). Make sure you remove foreign matter from:
 - The hopper (2a).
 - The slide ways in the tailgate (2b).
 - The gap between the carriage plate and retaining plate (2c).
 - The bottom end of the carriage plate/carriage plate cylinder bearing block (2d).
 - The area where hydraulic cylinders close into the body or small spaces (2e).
3. Clean each body in front of the ejection plate.
 - Make sure that all debris and foreign matter is removed from the sump and that the body drain hose is clear (3a).
 - Make sure you remove foreign matter from the slide ways in the body (3b).
4. Clean the tailgate pivots.

6.7.2 Lubricate hinges and linkages

1. Lubricate hinges and linkages (see '6.6 Lubrication' on page 6-5).

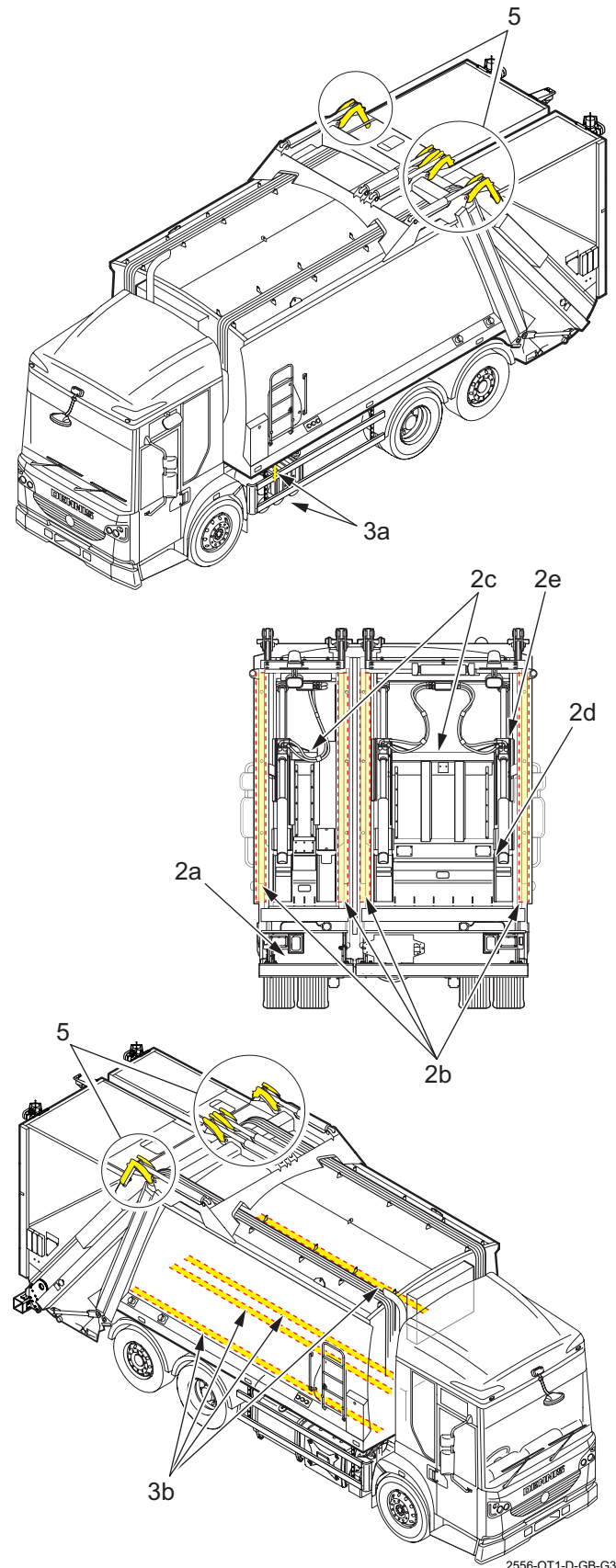

Fig. 6-3 Body tailgate cleaning points

2556-OT1-D-GB-G3



6.8 6-Week service checks

The following service checks should be carried out once every 6 weeks or more frequently when the Refuse Collection Vehicle is operating in severe conditions.

The following service checks should be carried out in addition to the Daily Service Checks and Weekly Service Checks.

1. Immobilise the vehicle (see '1.2 Immobilising the vehicle prior to service procedures' on page 1-3).

6.8.1 Check the security of body mounting bolts

Check that body mounting bolts and tightened to the specified torques, and spring lengths and gaps are correct.

Ref.	Components	Size	Spring length **/ gap † mm		
				Nm	lbf ft
1	Front body mounting bolts.	M24 x 80		1000	740
2	Front body mounting bolts.	M20 x 190	**65		
3	Intermediate body mounting bolts.	M24 x 170	±5		
4	Intermediate body mounting bolts.	M24 x 170	**70		
5	Intermediate body mounting bolts.	M16 x 60		150	110
6	Intermediate support blocks.	M12 x 80		101	75
7	Intermediate support blocks.	M12 x 40		101	75
8	Rear body mounting bolts.	M24 x 58		1000	740
9	Rear body mounting bolts.	M16 x 60		150	110

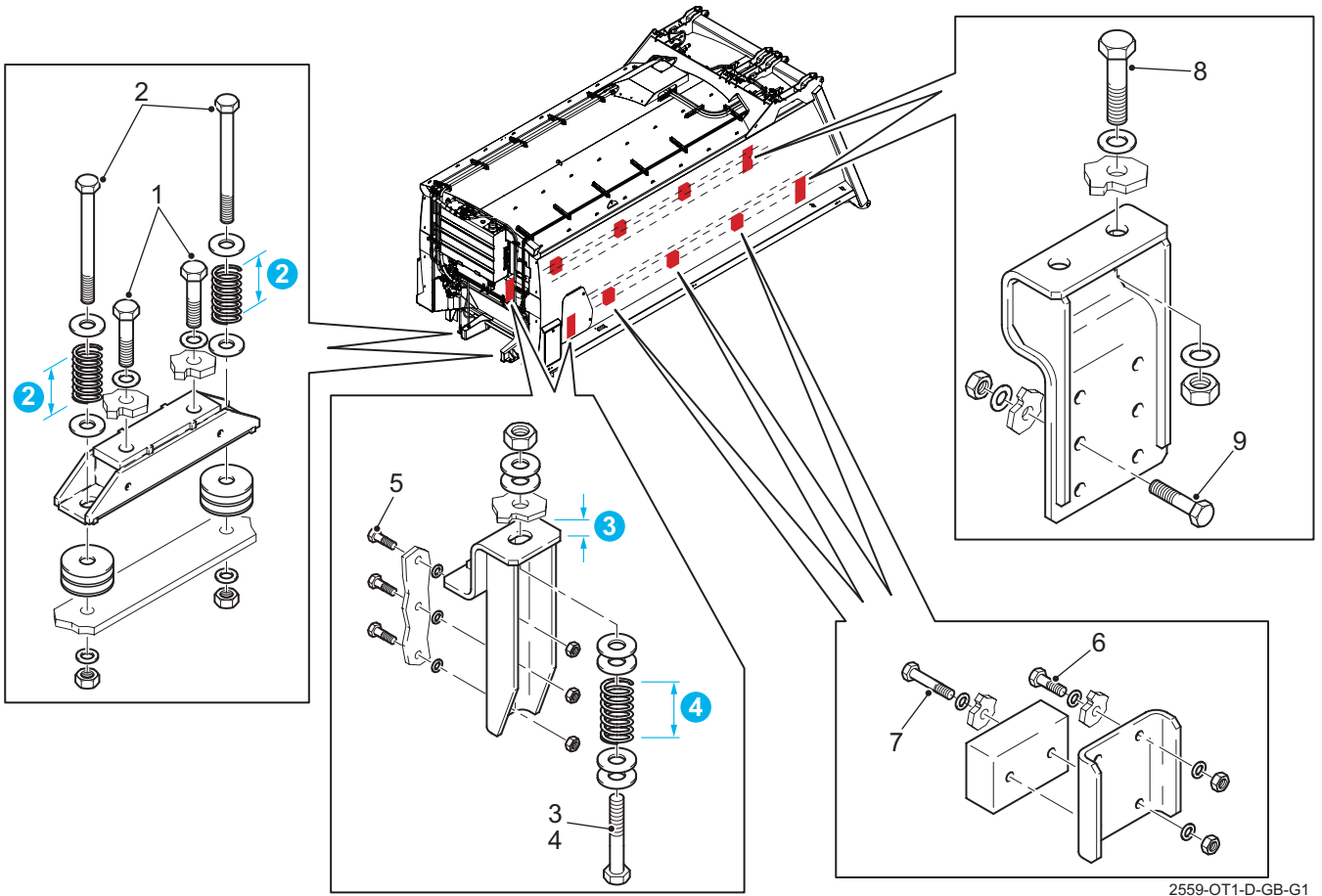

6

2559-OT1-D-GB-G1

Fig. 6-4 Body mounting bolts



6.8.2 Clean the tailgate proximity switches

1. Remove the tailgate side covers (1) and clean the tailgate proximity switches (2).
 - Carefully wipe any dirt away from the face of each proximity switch and its operating plate (3).

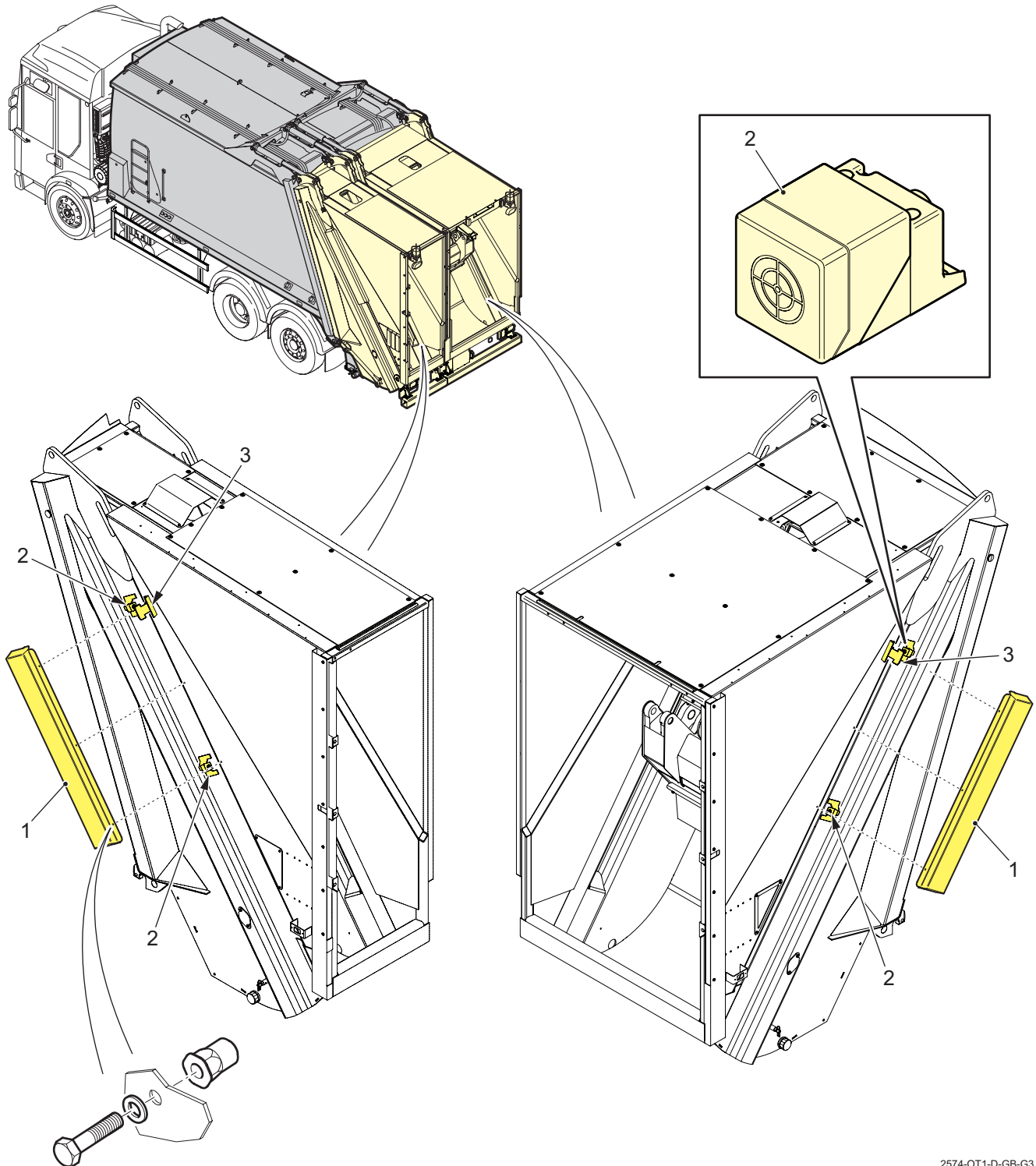

Fig. 6-5 Tailgate proximity switches

2574-OT1-D-GB-G3



6.9 12-Week service checks

The following service checks should be carried out every 12 weeks or more frequently when the Refuse Collection Vehicle is operating in severe conditions.

The following service checks should be carried out in addition to the Daily Service Checks, Weekly Service Checks and 6-Week Service Checks.

1. Stand the vehicle on clean, level and stable ground.
2. Prop both tailgates (see Operator's Handbook).
3. Immobilise the vehicle (see '1.2 Immobilising the vehicle prior to service procedures' on page 1-3).

6.9.1 Body checks

1. Check that the body is sitting square on the chassis.
2. Examine the condition of the following body components for security, displacement, wear, distortion, cracks, damage or corrosion, which affect their strength or operation. Make sure that brackets, fixings, welds and bolts are secure and not creating a danger to other users:
 - Body load bearing members near the mounting points.
 - Tailgate load-bearing members near the mounting points.
 - Tailgate lock pins.
 - Cylinder mountings and pivots.
 - Body access doors and their hinges, locks and switches.
 - Ejection plates.
 - Ejection plate guides.
 - Ejection plate slide blocks.
3. Check that structural (stressed) panels are not damaged or worn to less than 75% of their original thickness.

6.9.2 Tailgate checks

For each tailgate:

1. Check that the tailgate is sitting square on the body.
2. Check that the carriage plate assembly is sitting square in its tailgate.
3. Examine the condition of the following body components for security, displacement, wear, distortion, cracks, damage or corrosion, which affect their strength or operation. Make sure that brackets, fixings, welds and bolts are secure and not creating a danger to other users:
 - Tailgate pivots.
 - Rave rail.
 - Tailgate lock hooks.
 - Packer plate.
 - Packer plate pivot pins and bushes.
 - Carriage plate guides.
 - Carriage plate.
 - Carriage plate slide blocks.

Note: Since the carriage plate is subjected to rough treatment, superficial damage that does not affect the strength of the component is not a reason for rejection.

4. Check that gap between the carriage plate and refuse retaining plate is between 1 - 5 mm.
5. Examine the condition of the tailgate seal for security, damage, wear, shape, bulging, splits or perishing.



6.9.3 Hydraulic system components checks

1. Examine the following hydraulic system components and their mountings for, security, fractures, displacement, wear, distortion, cracks, damage, leaks or corrosion. Check that all split pins and washers are present and undamaged.
 - Hydraulic tank.
 - Hydraulic pumps.
 - Hydraulic filters.
 - Main valve block.
 - Ejector cylinder.
 - Packer plate cylinders (2 off).
 - Carriage plate cylinders (2 off).
 - Tailgate raise lower cylinders (2 off).
2. Check all rigid hydraulic pipes for, security, fractures, displacement, wear, distortion, cracks, damage, leaks, corrosion, fouling by moving parts, or chafing.
 - Where pipes are held by clips or supported by other means, ensure all clips and supporting devices are present and securely attached and fastened.
3. Check all flexible hydraulic hoses for, security, fractures, displacement, wear, distortion, cracks, damage, leaks, corrosion, deterioration, stretching or twisting, fouling by moving parts, or chafing.
 - Make sure hoses have sufficient room to move as necessary without fouling any part of the vehicle.
 - Make sure there are no sharp bends.
 - Check for signs of exposure to excessive heat.
 - Leaks - particularly when the system is in operation.
 - Check for signs of weakness or bulging - particularly when under maximum pressure.
 - Check for signs of perishing on the outer cover.

6.9.4 Electrical system checks

1. Examine all the electrical wiring looms, their connectors, wires and mountings for, condition, security, fractures, displacement, wear, distortion, cracks, damage, or corrosion.
 - Adequate insulation.
 - Check that the position of cables will not cause damage by chafing or heat such that the insulation becomes ineffective.
2. Examine the following electrical system components, connectors, wires and their mountings for, security, fractures, displacement, wear, distortion, cracks, damage, or corrosion.
 - Cab control panel.
 - Body electrical junction box.
 - External discharge control panel (when fitted).
 - Tailgate lower control panel.
 - Tailgate control panels (2 off).
 - Emergency stop buttons (2 off).
 - Carriage plate proximity switches (2 off).
 - Packer plate proximity switches (2 off).
 - Reversing buzzer.
3. Examine the following lamps, connectors, wires and their mountings for, security, fractures, displacement, wear, distortion, cracks, damage, or corrosion. Check that the lenses are present, are the correct colour and are not cracked or damaged or obscured.
 - Warning beacons.
 - Marker lamps.
 - Load lamps.
 - High level rear lamps.
 - Rear lamps.
 - Number plate lamps.

6.9.5 Power Take-Off propeller shaft (if fitted)

1. Examine the Power Take-Off propeller shaft universal joints for security, worn bearings, damage to grease seals and cracks.
2. Examine the Power Take-Off propeller shaft flange nuts for security and condition.
3. Examine the Power Take-Off propeller shaft slider joint and grease seal for wear and damage.



6.9.6 Hand wash unit (optional item)

1. Check the hand wash unit for, security of mounting, damage, corrosion and leaks.
2. Check that it operates to specification.

6.9.7 Operational check

1. Unprop the tailgates (see Operator's Handbook).
2. Carry out a full operational check of the body and tailgate systems as described in Chapter 3 - 'Daily checks'.
3. Check that all lamps and warning lamps emit light of the correct colour, do not flicker and that their illumination is not affected by the operation of any other lamp or equipment.
4. Check that the audible warning devices, if fitted, emit sounds correct to specification.

6.9.8 Compaction mechanism cycle time check

Check the compaction mechanism cycle time for each compaction mechanism as follows:

1. Start engine.



WARNING:
MAKE SURE THAT ALL PERSONNEL ARE CLEAR OF THE BODY, TAILGATE AND REAR OF THE VEHICLE.

2. Energise the compaction mechanism control panels (see Operator's handbook, 'Energising the control panels').
3. Depress the 'Start pack cycle' push-button on the compaction mechanism control panel to activate packing cycle and leave in the fully packed position.
4. Depress the 'Start pack cycle' push-button on the compaction mechanism control panel again and time one complete cycle - it should be between 18 to 20 secs (body & hopper empty).

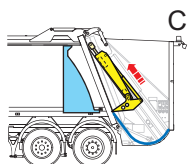
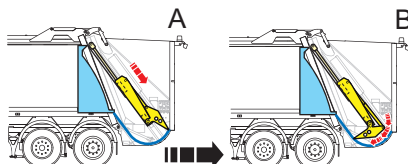
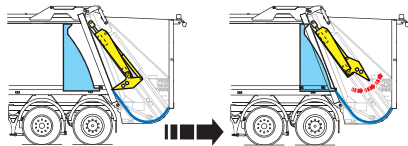

2563-OT1-D-GB-G1

6.9.9 Tailgate lower time check

Check the tailgate lower time for each tailgate as follows:

1. Start engine.



WARNINGS:
MAKE SURE THAT ALL PERSONNEL ARE CLEAR OF THE BODY, TAILGATE AND REAR OF THE VEHICLE.

MAKE SURE THAT YOU KNOW THE HEIGHT OF YOUR VEHICLE WITH THE TAILGATE AND WASTE CONTAINER LIFTING DEVICE, IF FITTED, RAISED.

2. Energise the discharge control panel and fully raise the tailgate (See Operator's handbook, 'Discharging Refuse').
3. Press the two push-buttons on the 'Tailgate lowering' control panel simultaneously to lower the tailgate fully into its locks and check that the time taken for the tailgate to lower and engage its locks exceeds 20 seconds.



6.10 12-Month service checks

The following service checks should be carried out every 12 months or more frequently when the Refuse Collection Vehicle is operating in severe conditions.

The following service checks should be carried out in addition to the Daily Service Checks, Weekly Service Checks, 6-Week Service Checks and 12-Week Service Checks.

6.10.1 Renew hydraulic oil filter elements

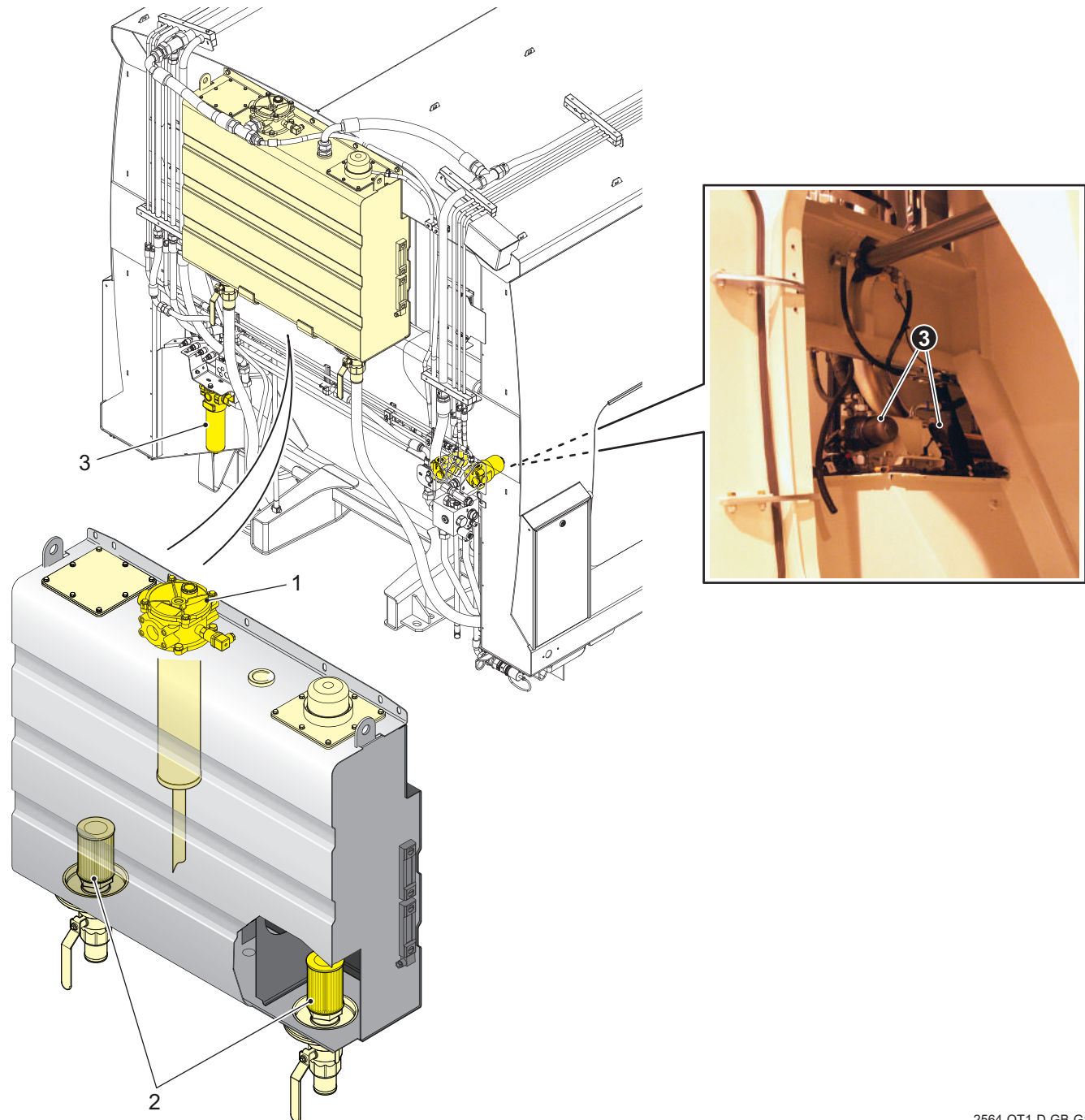

Fig. 6-6 Hydraulic oil filters

1. Return line oil filter.
2. Strainer filter.
3. High pressure oil filter.

2564-OT1-D-GB-G1



1. Thoroughly clean the area around the filters.
2. Immobilise the vehicle - (see '1.2 Immobilising the vehicle prior to service procedures' on page 1-3).
3. Tilt the cab (refer to chassis-cab manufacturer's instructions).
4. Place drip trays under the body functions control valve block and the hydraulic tank to collect any spilt oil.

High pressure oil filter

5. Unscrew the filter bowl.
6. Remove the filter element and O-rings.
7. Make sure that oil drains into the drip tray for disposal.
8. Clean out any sediment that may have settled in the bottom of the bowl and the O-ring locations.
9. Fit new O-rings and a new filter element.
10. Install the filter bowl assembly and tighten to 20.4 Nm (15 lbf ft).

Return line oil filter

11. Remove the 4 screws securing the filter head cover plate.
 12. Remove the square section sealing ring from the cover plate and fit a new one.
 13. Remove the filter element and insert a new filter element.
 14. Fit the filter head cover plate and tighten the screws to 20.4 Nm (15 lbf ft).
 15. Start the engine and check for leaks.
 16. Stop the engine.
 17. Clean filter assembly, remove drip trays and clean up any spillage that may have occurred.
 18. Lower the cab (refer to chassis-cab manufacturer's instructions).
 19. Close the body access door.
 20. Check level of oil in hydraulic oil tank and top up if required (see '4.1 To check hydraulic system oil level' on page 4-3).
 21. Dispose used filters in accordance with legislation or code of practice regarding disposal of controlled materials and oils.
- Service exchange filters are available. Contact Dennis Eagle Ltd., Parts Department.



6.11 24-Month hydraulic system oil quality check/ 36-month hydraulic system oil change

The strainer filters and hydraulic system oil should be changed at every 36 months.

- It is recommended that at 24 months from delivery of the vehicle or from changing the hydraulic system oil, a sample of the hydraulic oil should be taken from the hydraulic tank and analysed by a qualified laboratory.
- Refer to Olympus Twin Pack Workshop manual for procedure.

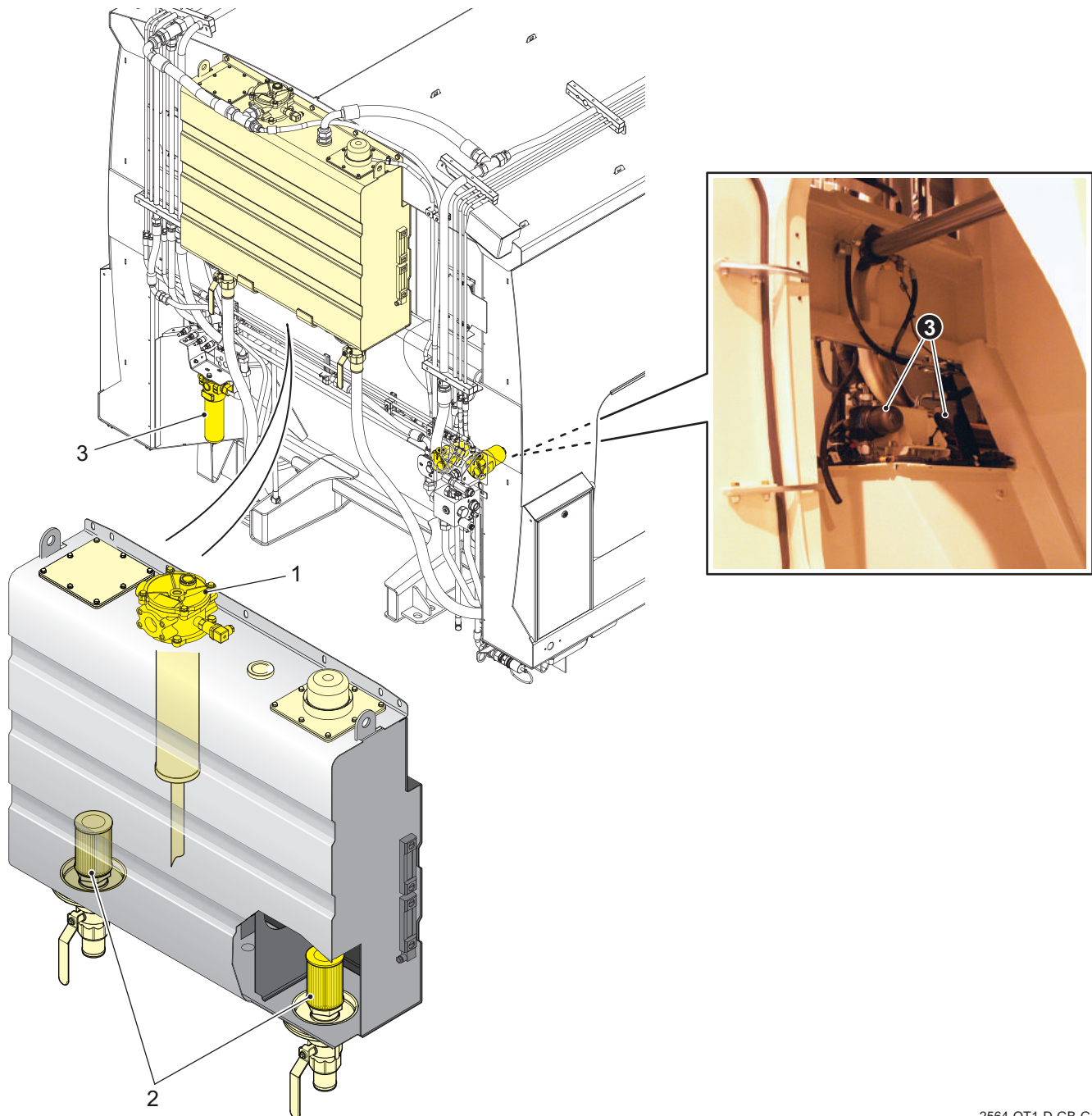

Fig. 6-7 Hydraulic oil filter and breather filter

1. Return line oil filter.
2. Strainer filter.
3. High pressure oil filter.

2564-OT1-D-GB-G1



Olympus Twin Pack Service Manual

CONTENTS		PAGE
7	Operational maintenance	7-2
7.1	Bodywork lamp bulb replacement	7-2
7.2	Fuses and relays	7-2
7.2.1	Left-hand body box	7-2
7.2.2	Right-hand body box.....	7-4
7.3	Setting the clock/calendar	7-6



OPERATIONAL MAINTENANCE

7 Operational maintenance

7.1 Bodywork lamp bulb replacement

All bodywork lamps are LED lamps and do not feature replaceable bulbs.

7.2 Fuses and relays

7.2.1 Left-hand body box

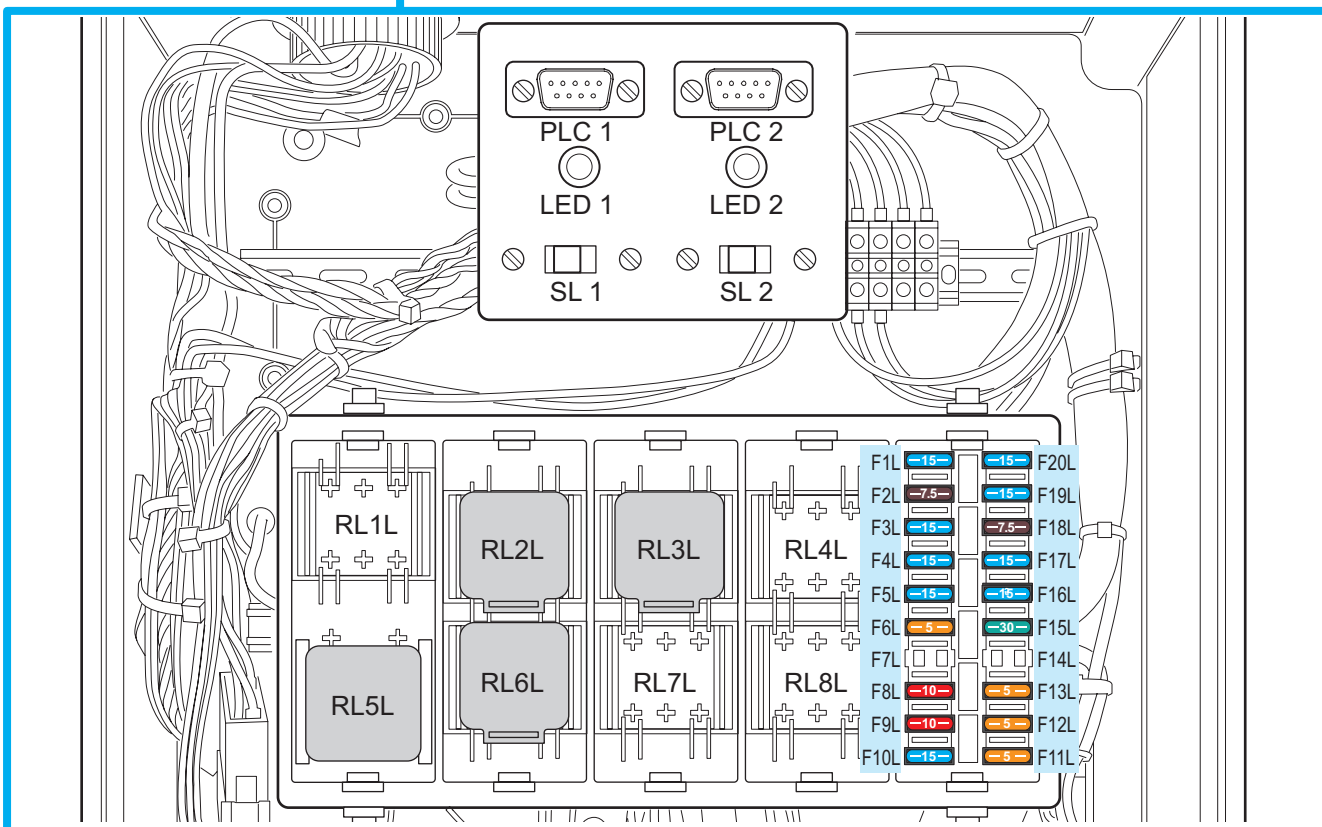
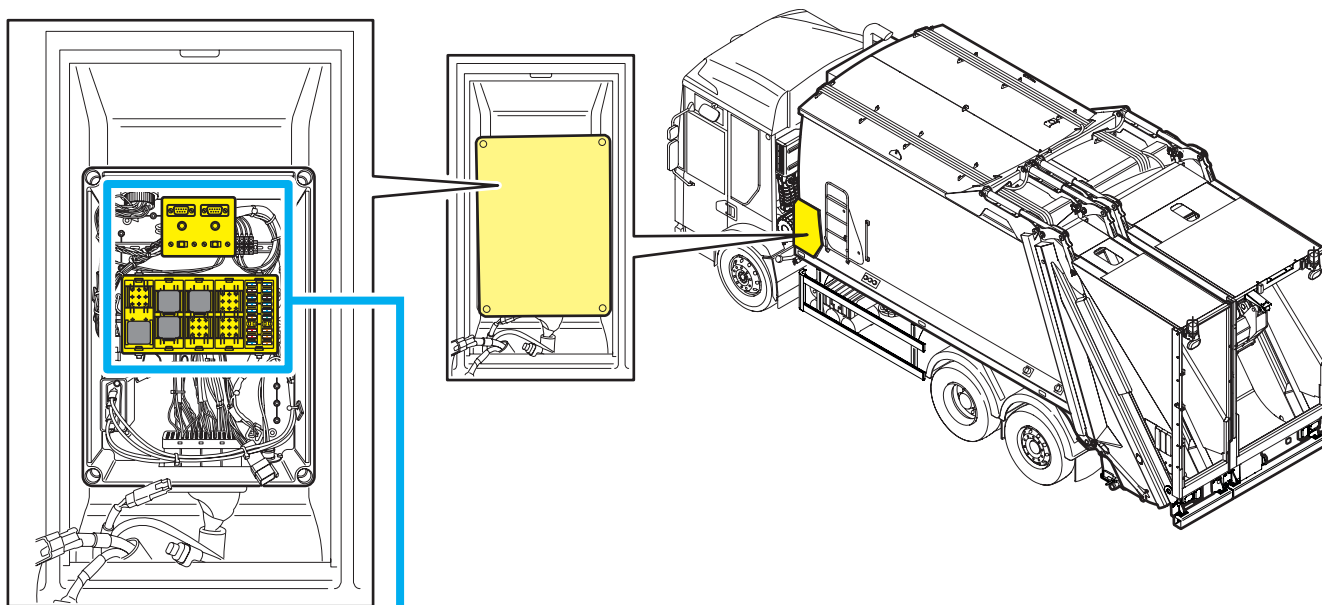

3876-0T1-D-GB-G2



Fuses

Fuse	Function	Fuse rating
F1L	Spare.	15A
F2L	Ignition supply work lamps relay RL3L.	7.5A
F3L	Supply to PLC2-5 power for module.	15A
F4L	Supply to PLC1 outputs via PLC1-5.	15A
F5L	Supply to PLC1 outputs via PLC1-34.	15A
F6L	Supply to emergency stop circuits into PLC1.	5A
F7L		
F8L	24 volt supply to: <ul style="list-style-type: none"> • left-hand body full switch, • left-hand access door switch, • oil filter blocked sensors, • left-hand tailgate angle sensor, • left-hand packer plate position sensor, • left-hand carriage plate down sensor, • left-hand carriage plate up sensor, • left-hand hydraulic oil pressure transducer, • left-hand adaption frame switch, • left-hand footboard switch. 	10A
F9L	24 volt supply to left-hand waste container lifting device connection.	10A
F10L	Options, 24 volt supply to zone safe and body weighing system.	15A
F11L	Supply to PLC1-23 power for module.	5A
F12L	24 volt supply to: <ul style="list-style-type: none"> • left-hand programming switches, • relay RL6L, • left-hand tailgate raise switch, • left-hand retract switch, • left-hand eject switch, • left-hand eject switch, safe, • left-hand tailgate lower switches, • left-hand call switch, • left-hand reverse/rescue switch, • right-hand call switch, • right-hand reverse/rescue switch, • left-hand manual carriage plate up switch, safe, • right-hand manual carriage plate up switch, safe. 	5A
F13L	Supply to PLC2-23 power for module.	5A
F14L		
F15L	Power supply to load dump.	30A
F16L	Spare.	15A
F17L	Spare.	15A
F18L	Supply to warning beacons relay RL2L.	7.5A
F19L	Supply to PLC2-34 power for module.	15A
F20L	24 volt supply to 'One Pass' connection.	15A

Relays

Relay	Function
RL1L	
RL2L	Warning beacons.
RL3L	Work lamps.
RL4L	
RL5L	Ignition left.
RL6L	Control station.
RL7L	
RL8L	



7.2.2 Right-hand body box

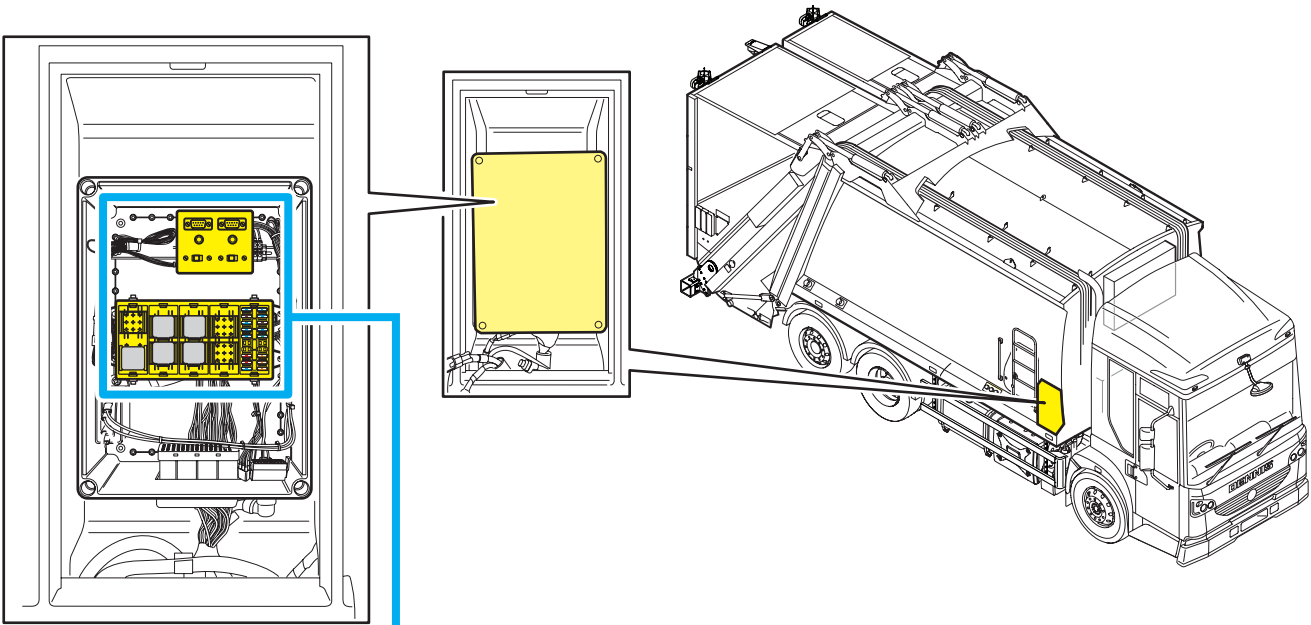

7

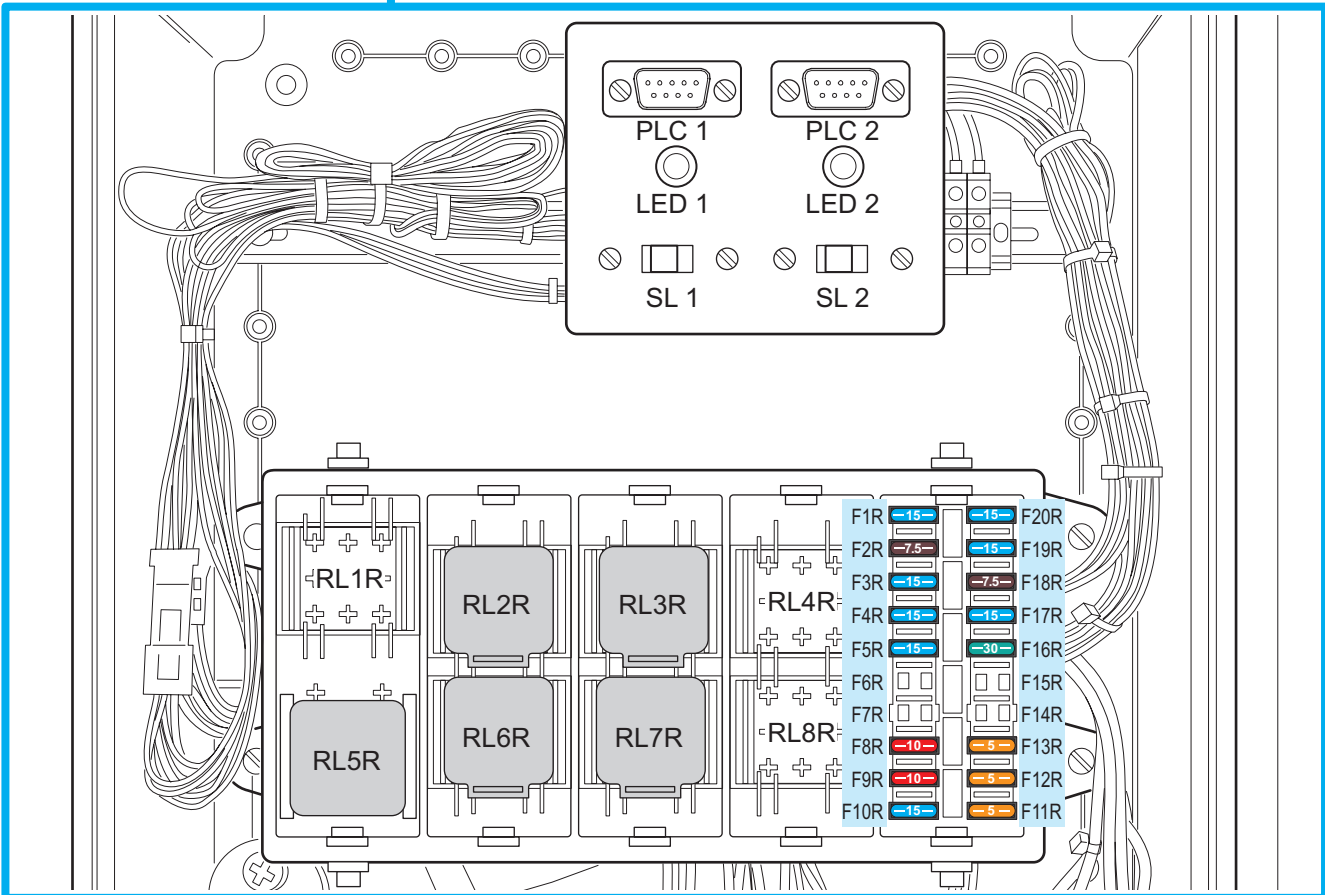

3879-OT1-D-GB-G2



Fuses

Fuse	Function	Fuse rating
F1R		15A
F2R	Ignition supply work lamps relay RL3R.	7.5A
F3R	Supply to warning beacons Relay RL2R.	15A
F4R	Supply to PLC3 outputs via PLC3-5.	15A
F5R	Supply to PLC3 outputs via PLC3-34.	15A
F6R		
F7R	Supply to Spare Relay SPP2.	15A
F8R	Supply to PLC3 outputs via PLC3-23.	10A
F9R	Supply to PLC4 outputs via PLC4-23.	10A
F10R	24 volt supply to: <ul style="list-style-type: none"> right-hand programming switches, relay RL7R, right-hand tailgate raise switch, right-hand retract switch, right-hand eject switch, right-hand eject switch, safe right-hand tailgate lower switches, right-hand call switch, right-hand reverse/rescue switch, left-hand call switch, left-hand reverse/rescue switch, left-hand manual carriage plate up switch, safe, right-hand manual carriage plate up switch, safe. 	15A
F11R	24 volt supply to: <ul style="list-style-type: none"> right-hand body full switch, right-hand access door switch, oil filter blocked sensor tank, oil filter blocked sensor block, oil level switch, oil temperature switch, right-hand tailgate angle sensor, right-hand packer plate position sensor, right-hand carriage plate down sensor, right-hand carriage plate up sensor, right-hand hydraulic oil pressure transducer, right-hand adaption frame switch, right-hand footboard switch. 	5A
F12R	24 volt supply to right-hand lifting device connection.	5A
F13R	Supply for CR2012 option board.	5A
F14R		
F15R		
F16R	Power supply to load dump.	30A
F17R	24 volt supply to electric clutch.	15A
F18R	Supply to PLC4-34 power for module.	7.5A
F19R	Supply to PLC4-5 power for module.	15A
F20R	Supply to Emergency Stop Circuits into PLC3.	15A

Relays

Relay	Function
RL1R	
RL2R	Warning beacons.
RL3R	Work lamps.
RL4R	
RL5R	Ignition right.
RL6R	Control station.
RL7R	Electric clutch.
RL8R	



7.3 Setting the clock/calendar

To set any of the clock or calendar values:

1. Make sure the vehicle is stationary with the parking brake applied, the 'Body main' switch off and the ignition switched off.
2. Simultaneously press and hold the top and bottom buttons on the left-hand side of the screen.



2482-OT1-D-GB-G1

3. While continuing to press top and bottom buttons, turn the ignition to position 'M' (ignition on).
 - The screen will commence initialising.

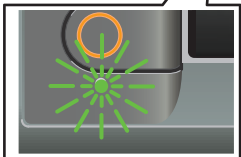
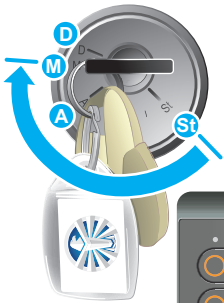

2481-OT1-D-GB-G2

4. After 6 seconds release the top and bottom buttons.
 - The screen will continue to initialise and then show the 'SET UP' screen.
 - If 'SET UP' is not highlighted by a black border, turn the encoder control, or press the switches labelled 'UP' or 'DOWN', until it is.

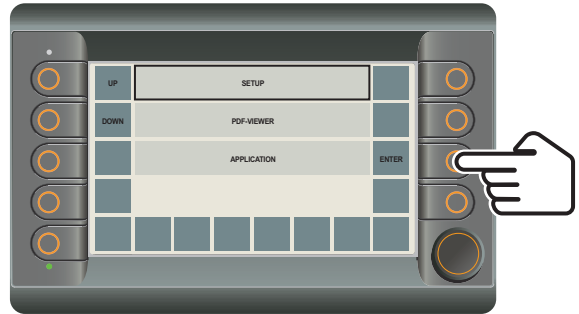

2483-OT1-D-GB-G1

5. Press and release the switch labelled 'ENTER'.
 - The screen should show the 'SYSTEM SETTINGS' screen.
 - If 'SYSTEM SETTINGS' is not highlighted by a black border, turn the encoder control, or press the switches labelled 'SELECT' or 'BACKSEL', until it is.

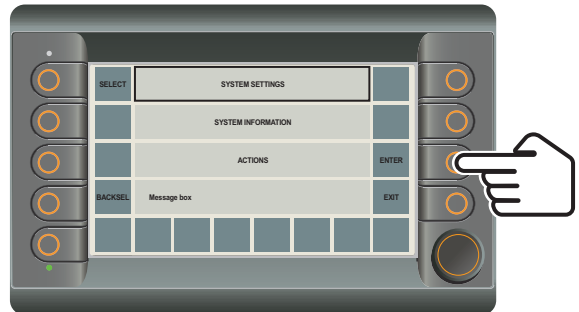

2494-OT1-D-GB-G1



OPERATIONAL MAINTENANCE

- Press and release the switch labelled 'ENTER'.
 - 'ETHERNET' will be highlighted by a black border.

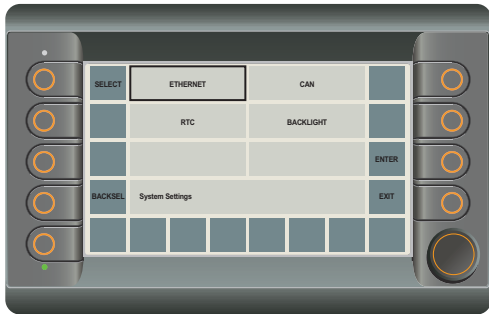

2495-OT1-D-GB-G1

- Press and release the switch labelled 'ENTER'.
 - The clock calendar adjustment screen will show.

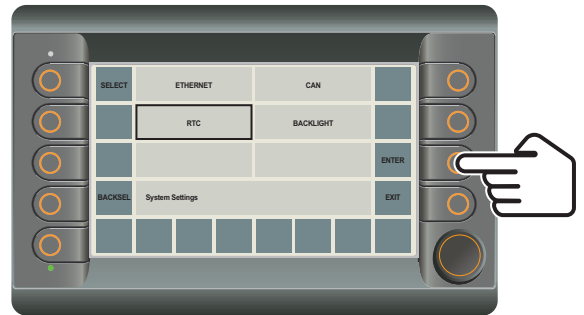

- Turn the encoder control, or press the switches labelled 'SELECT' or 'BACKSEL', until RTC is highlighted by the black border.

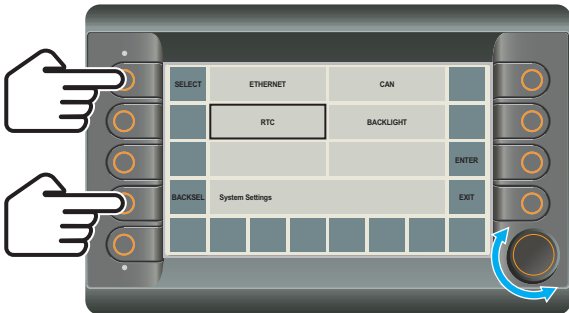

2496-OT1-D-GB-G1

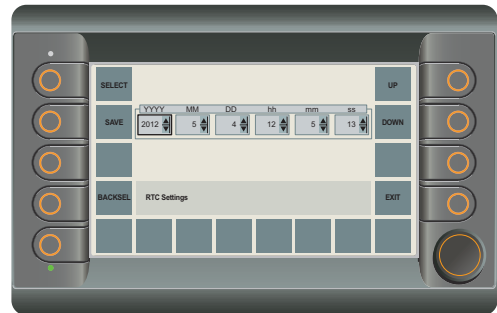

2497-OT1-D-GB-G1

- Turn the encoder control, or press the switches labelled 'SELECT' or 'BACKSEL', until the border surrounds the parameter to be changed:
 - YYYY = Year.
 - MM = Month.
 - DD = Day.
 - hh = hours.
 - mm = minutes.
 - ss = seconds.

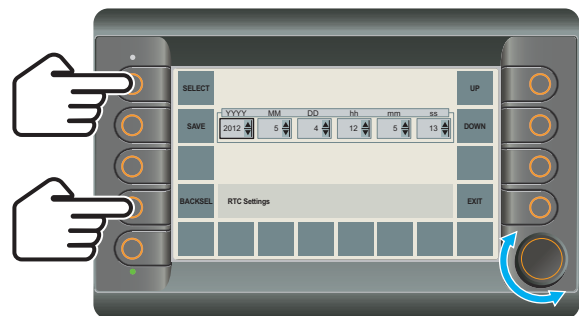

2498-OT1-D-GB-G1

- Press the switches labelled 'UP' or 'DOWN' as required to change the parameter value.



10. If other parameters require changing, repeat operations 8 & 9 until all the all the parameters are correct.
11. When all of the parameters have been adjusted, press and release the switch labelled 'SAVE'.
 - The screen will show 'Saving..... Done'.

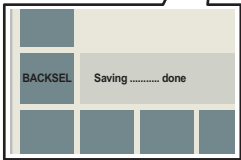
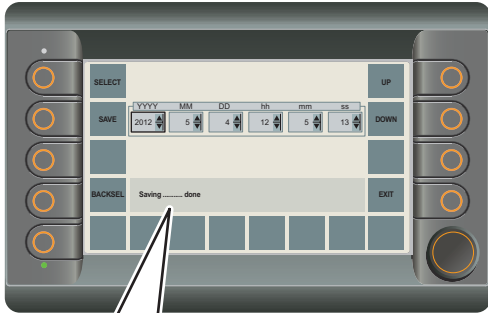

2499-OT1-D-GB-G1

12. Press and release the switch labelled 'EXIT'.
 - The screen will return to the 'SET UP' screen.

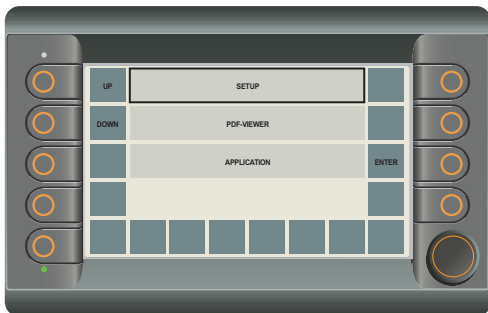
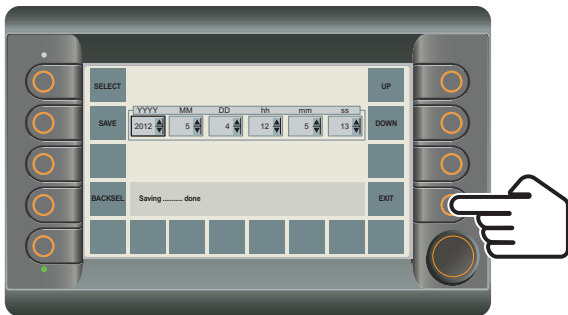

2500-OT1-D-GB-G1

13. Turn the encoder control, or press the switches labelled 'UP' and 'DOWN', until 'APPLICATION' is highlighted by the black border.

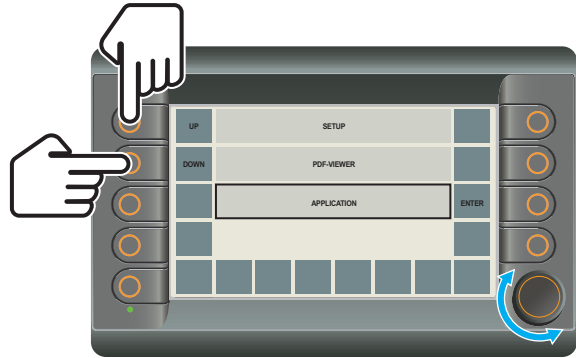

2530-OT1-D-GB-G1

14. Press and release the switch labelled 'ENTER'.
 - The screen will return to the 'Start up' screen

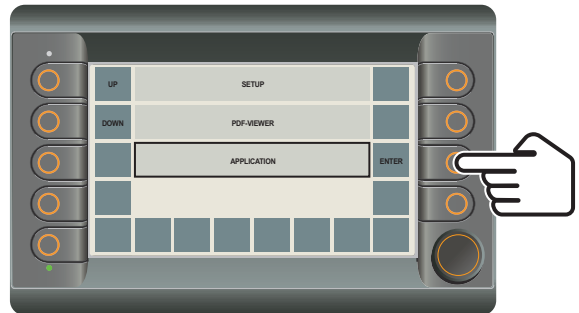

2532-OT1-D-GB-G2

15. Turn the ignition off.



16. Turn the ignition on.
17. After initialising, the clock calendar values shown on the screen will be changed to the new settings.

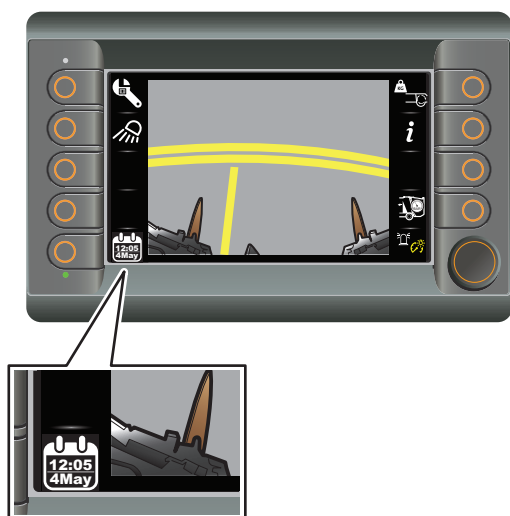

2534-OT1-D-GB-G3



This page intentionally left blank



Olympus Twin Pack Service Manual

CONTENTS		PAGE
8	General specification data	8-2
8.1	Dimensions, Olympus Twin Pack series.....	8-2
8.2	Vehicle data sheets, masses and dimensions.....	8-4
8.3	Vehicle Stability calculations	8-4
8.4	Typical operation times	8-4
8.4.1	Cycle time	8-4
8.4.2	Ejection plate.....	8-4
8.4.3	Tailgate raise/lower	8-4
8.5	Noise level.....	8-4
8.6	Vibration levels.....	8-4
8.6.1	Hand-arm vibration	8-4
8.6.2	Whole-body vibration	8-4
8.7	Hydraulic pressures	8-4
8.8	Hydraulic oils and greases.....	8-5
8.9	Body identification label	8-6



8 General specification data

8.1 Dimensions, Olympus Twin Pack series

Dennis Eagle Elite 6 municipal chassis-cab fitted with 'Smooth sided' twin pack full width (2.53 m) refuse collection bodywork.



2542-OT1-D-GB-G4

Vehicle model		OLTP-16	OLTP-19	OLTP-22	OLTP-27 8x4MS
Elite chassis-cab type		6x2ML (Mid Lift) Wide Track	6x2ML (Mid Lift) Wide Track 6x2MS (Mid Steer) Wide Track	6x2ML (Mid Lift) Wide Track 6x2MS (Mid Steer) Wide Track 6x2RS (Rear Steer) Wide Track 6x4 Wide Track	8x4MS (Mid Steer) Wide Track
WB	Overall wheelbase.	4300	4750	5250	6400
W	Overall width.	2550	2550	2550	2550
H1	Overall height (exhaust tip).	3750	3750	3750	3750
H2	Overall height-tailgate raised.	5190	5190	5190	5190
H3	Height to top of body.	3690	3690	3690	3690
H4	Manual loading height (Open-back).	1070	1070	1070	1070
C1	Ground clearance - rear - unladen.	250	250	250	250
C2	Approach angle.	15.5°	15.5°	15.5°	15.5°
C3	Departure angle.	15°	15°	15°	15°

Note: Unless otherwise stated, all dimensions are nominal, in mm and represent an unladen vehicle without a waste container lifting device and fitted with standard tyres; tyre deflection is not included. On vehicles equipped with optional air suspension, heights may differ. All specifications are subject to manufacturers tolerances. An allowance of +/- 2% should be made for all weights. All weights are in kgs and include oil and water, and on diesel fuelled vehicles, AdBlue and 50 litres of fuel. Additional equipment may alter dimensions and weights quoted.



GENERAL SPECIFICATION DATA

Dennis Eagle Elite 6 municipal chassis-cab fitted with 'Smooth sided' twin pack narrow width (2.30 m) refuse collection bodywork.



Vehicle model		OLTP-13N	OLTP-17N
Elite chassis-cab type		4x2 Narrow Track	6x2RS (Rear Steer) Narrow Track
WB	Overall wheelbase.	4300	5250
W	Overall width.	2300	2300
H1	Overall height (exhaust tip).	3500	3500
H2	Overall height-tailgate raised.	4950	4950
H3	Height to top of body.	3450	3450
H4	Manual loading height (Open-back).	1070	1070
C1	Ground clearance - rear - unladen.	250	250
C2	Approach angle.	15.5°	15.5°
C3	Departure angle.	15°	15°

Note: Unless otherwise stated, all dimensions are nominal, in mm and represent an unladen vehicle without a waste container lifting device and fitted with standard tyres; tyre deflection is not included. On vehicles equipped with optional air suspension, heights may differ. All specifications are subject to manufacturers tolerances. An allowance of +/- 2% should be made for all weights. All weights are in kgs and include oil and water, and on diesel fuelled vehicles, AdBlue and 50 litres of fuel. Additional equipment may alter dimensions and weights quoted.



8.2 Vehicle data sheets, masses and dimensions

Data sheets, incorporating information conforming to the requirements of EN1501-1, specific to the individual chassis/bodywork and lifting device are supplied to the original owner of the vehicle as part of the vehicle purchasing process.

8.3 Vehicle Stability calculations

Vehicle Stability calculations, incorporating information conforming to the requirements of EN1501-1, specific to the individual chassis/bodywork and lifting device are supplied to the original owner of the vehicle as part of the vehicle purchasing process.

8.4 Typical operation times

8.4.1 Cycle time

Cycle time with an empty tailgate = 18 - 20 seconds.

8.4.2 Ejection plate

Eject Stroke = 25 - 35 seconds.

Note: Ejection plate times are approximate because of friction on the tracks.

Times may vary depending on body size and type of refuse.

8.4.3 Tailgate raise/lower

Tailgate raise = 17 - 21 seconds.

Tailgate lower = 20 - 35 seconds.

8.5 Noise level

The maximum A-weighted sound pressure level at operator's work-stations is less than or equal to 85 dB(A).

8.6 Vibration levels

8.6.1 Hand-arm vibration

The maximum weighted root mean square acceleration emission that the arms of the operative are subjected to is less than or equal to 2.5 m/s².

8.6.2 Whole-body vibration

The maximum weighted root mean square acceleration emission that the body of the operative is subjected to is less than or equal to 0.5 m/s².

8.7 Hydraulic pressures



WARNING:

IF A FAULT OCCURS WITH THE MECHANISM OR THE FUNCTION TIMES ARE ERRATIC REPORT THE FAULT TO SUPERVISION IMMEDIATELY. DO NOT ATTEMPT TO MAKE ANY HYDRAULIC ADJUSTMENTS AS THIS WILL COMPROMISE SAFETY AND NULLIFY ANY WARRANTY AGREEMENTS WITH DENNIS EAGLE LTD.



8.8 Hydraulic oils and greases

Recommended hydraulic oil				
Temperature range	BS 4231 Viscosity grade	ISO Oil type	Manufacturer's specification	Note
-30° to +80°	32	HM	Q8 Foil 32	Biodegradable viscosity 46 oil is used where specified by customers.

Recommended greases	
Application	Manufacturer's specification
General lubrication	Shell Retinax A BP Energol LS2 or L2 Castrol LM Total EP2 Energol HLP32.
Carriage plate/Packer plate pivot pins	Fuchs Renolit Aqua 2 or similar lubricant to DEF STAN 91-34/1



GENERAL SPECIFICATION DATA

8.9 Body identification label

The body identification label is now affixed to right-hand drain box.

The information on the label is shown below:

Machine category / Body type.

Serial number.

Order number.

Year of manufacture.

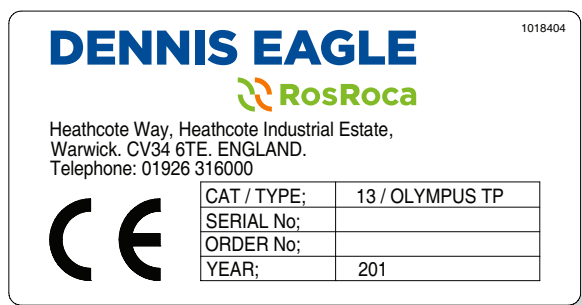

8

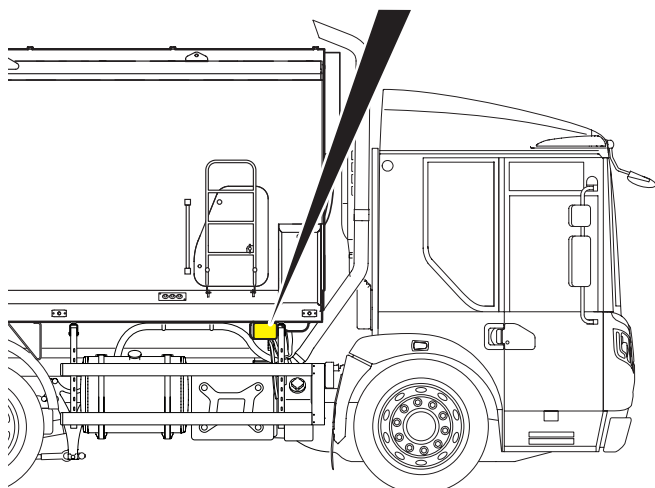

3821-OT1-D-GB-G2



Olympus Twin Pack Service Manual

CONTENTS	PAGE
9 Supplementary information	9-2



SUPPLEMENTARY INFORMATION

9 Supplementary information

Supplementary information/owners comments

This page has been left blank to enable supplementary information to be incorporated in the handbook or for the owner to make notes.



Supplementary information/owners comments

This page has been left blank to enable supplementary information to be incorporated in the handbook or for the owner to make notes.



SUPPLEMENTARY INFORMATION

Supplementary information/owners comments

This page has been left blank to enable supplementary information to be incorporated in the handbook or for the owner to make notes.



Supplementary information/owners comments

This page has been left blank to enable supplementary information to be incorporated in the handbook or for the owner to make notes.



SUPPLEMENTARY INFORMATION

Supplementary information/owners comments

This page has been left blank to enable supplementary information to be incorporated in the handbook or for the owner to make notes.



C

- Cleaning — **5-3**
 - Cleaning the leachate tank — **5-6**
 - Daily cleaning — **5-5**
 - Drain — **5-4**
 - Body drain — **5-4**
 - Tailgate drains — **5-4**
 - Pressure washing — **5-6**

D

- Daily checks — **3-3**
 - Daily safety checks — **3-3**
 - Warning labels — **3-28**

G

- General specification data — **8-2**
 - Dimensions
 - Body identification label — **8-6**
 - Dimensions, Olympus Twin Pack series — **8-2**
 - Hydraulic oils and greases — **8-5**
 - Hydraulic pressures — **8-4**
 - Typical operation times — **8-4**
 - Cycle time — **8-4**
 - Ejection plate — **8-4**
 - Tailgate raise/lower — **8-4**
 - Vehicle data sheets, masses and dimensions — **8-4**
 - Vehicle Stability calculations — **8-4**
 - Vibration levels — **8-4**
 - Hand-arm vibration — **8-4**
 - Whole-body vibration — **8-4**

H

- Health and safety — **2-3**
 - Cleaning a vehicle — **2-11**
 - Pressure washing — **2-11**
 - First aid and emergency treatment — **2-6**
 - Burns — **2-6**
 - Carbon monoxide poisoning — **2-6**
 - Contact with and/or ingestion of fluids — **2-6**
 - Cuts and wounds — **2-6**
 - Workshop first aid equipment — **2-6**

- Hydraulic and pneumatic systems — **2-13**
- Introduction — **2-3**
- Precautions and protection for personnel — **2-4**
 - Personal hygiene — **2-4**
 - Protective clothing — **2-4**
- Returning the vehicle to service — **2-13**
- Safety symbol, warnings, cautions and notes — **2-3**
- Trained personnel — **2-3**
- Use of these instructions — **2-3**
- Vehicle electrical systems — **2-12**
 - Disconnection and reconnection of electrical components — **2-12**
 - General electrical precautions — **2-12**
 - Welding on or near the vehicle — **2-12**
- Working at high level — **2-5**
- Workshop precautions, procedures and practices — **2-7**
 - Access and lifting equipment — **2-10**
 - Cleaning of equipment — **2-10**
 - Contact with plastic material residues after fires — **2-11**
 - Environmental protection precautions — **2-10**
 - Fasteners — **2-9**
 - Fuel, oil, lubricants, degreasants and filters — **2-10**
 - General workshop precautions — **2-8**
 - Hot components — **2-9**
 - Immobilising the vehicle — **2-8**
 - 'Live' work — **2-9**
 - Manual handling and movement of loads — **2-10**
 - Material safety data sheets — **2-7**
 - Moving or rotating parts — **2-8**
 - Protecting vehicle components during grinding, drilling and welding — **2-9**
 - Responsible technician, the Key Holder — **2-7**
 - Solvents — **2-10**
 - Welding on or near the vehicle — **2-9**
 - Workplace cleanliness — **2-8**
- Hydraulic system oil level — **4-3**
 - To check hydraulic system oil level — **4-3**
 - Topping up hydraulic oil - bulk oil supply — **4-8**
 - Topping up hydraulic oil - using hand pump — **4-9**



I

- Introduction — **1-3**
 - Immobilising the vehicle prior to service procedures — **1-3**
 - Safety precautions — **1-3**

O

- Operational maintenance — **7-2**
 - Body lamp bulb replacement — **7-2**
 - Fuses and relays — **7-2**
 - Setting the clock/calendar — **7-6**

S

- Scheduled maintenance — **6-3**
 - 6-Week service checks — **6-8**
 - Check the security of body mounting bolts — **6-8**
 - Clean the tailgate proximity switches — **6-10**
 - 12-Month service checks — **6-14**
 - Renew hydraulic oil filter elements and breather filter — **6-14**
 - 12-Week service checks — **6-11**
 - Body checks — **6-11**
 - Compaction mechanism cycle time check — **6-13**
 - Electrical system checks — **6-12**
 - Hand wash unit (optional item) — **6-13**
 - Hydraulic system components checks — **6-12**
 - Operational check — **6-13**
 - Power Take-Off propeller shaft (if fitted) — **6-12**
 - Tailgate checks — **6-11**
 - Tailgate lower time check — **6-13**
 - 24-Month hydraulic system oil quality check/
36-month hydraulic system oil change — **6-16**
- Introduction — **6-3**
- Lubrication — **6-5**
- Maintenance summary — **6-4**
- Noise level — **8-4**
- Operational maintenance — **6-3**
- Routine maintenance — **6-3**
- Warnings — **6-3**
- Weekly service checks — **6-7**
 - Clean the body and tailgate — **6-7**
 - Lubricate hinges and linkages — **6-7**
- Supplementary information — **9-2**