



HS SIDE LOADER SPEEDLINE ACE

LOW STRUCTURAL HEIGHT.
MAXIMUM POSSIBILITIES.

HS SPEEDLINE: MADE-TO-MEASURE COST-EFFECTIVE COLLECTIONS.



The highest efficiency for any operation: The HS Speedline side loader impresses both local authorities and private waste management companies, thanks to its powerful performance and intelligent design.

The Speedline ACE with minimal structural height and single pick-up for waste containers up to 360 l is ideally suited for low headroom passages and alleyways. The Speedline ACE is impressive with a powerful paddle press for all waste streams. Whether you're with a full crew or a single-operator, the HS Speedline ACE will always prove its worth as a high quality, efficient solution for your waste collection operations.

ABOUT HS FAHRZEUGBAU GMBH

HS Fahrzeugbau GmbH is our specialist subsidiary for the manufacture of cutting-edge waste & recycling collection vehicles. They combine more than 100 years of experience with innovation, thanks to their passion and high levels of quality. As part of the Terberg RosRoca Group, HS Fahrzeugbau are part of our strong network.

Everything from a single source: We support you with individual, integrated and cost-effective solutions – from planning, analysis and design to implementation, delivery and service.

Spare parts supply and service: Original spare parts are usually available within 24 hours subject to delivery wherever you are in the world.



OUR NEW MD4 CONTROL SYSTEM

Our MD4 controller with RAM mount saves space and is ergonomically mounted in the driver's cab without impairing their field of vision. All function parameters and event messages are clearly and comprehensibly displayed via the 7 or 10 inch touch screen (such as hydraulic oil level and target-actual bin lift speeds). The MD4 can also be accessed via Bluetooth for remote maintenance. The MD4 also enables you to retrieve saved PDF documents such as operating instructions and spare parts lists.

The MD4 controller also has the option to display visuals from IP cameras making interactive camera control possible.



HSS CIRCULAR ARC BIN LIFT

- High performance with twin pick-up
- Patented close proximity lifting
- Lifting capacity up to 270 kg
- 60 – 360 l waste containers



EVOLIFT GRABBER

- With two hydraulic rotary drives
- Lifting capacity of 240 kg
- 60 – 240 l waste containers



OPTIMISED DISCHARGE

- Rear tipping body with sloped container floor
- Superbly large tipping angle
- Smooth interior structure to ensure minimal sticking of materials during discharge
- Large rear opening

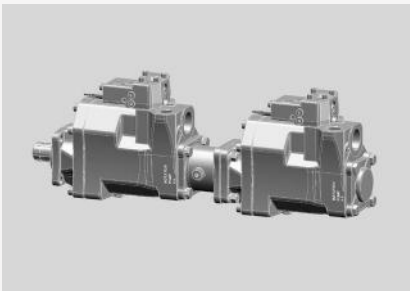

TWO VARIABLE DISPLACEMENT PUMPS WITH LOAD SENSING SYSTEM

- Simultaneous operation of the compaction and bin lift functions
- Helps reduce your energy consumption
- High waste collection performance
- Enable fast operation of the bin lift system



SLANTING REAR DOOR OPTION

- Short overhang for container emptying
- Serial chassis rear underride protection and light carrier



PADDLE COMPACTOR

- Low-maintenance and wear-resistant
- Fast packing cycles
- External cylinders



FLEX-ARMREST

- Fully adjustable armrest
- Selection of joystick designs

TECHNICAL CHARACTERISTICS OF HS SPEEDLINE ACE:

At HS Fahrzeugbau, you not only get state-of-the-art waste collection vehicles – you also get system solutions from a single source. And our side loaders are always tailored exactly to your requirements – **with equipment optimised for its application and state-of-the-art technology.**

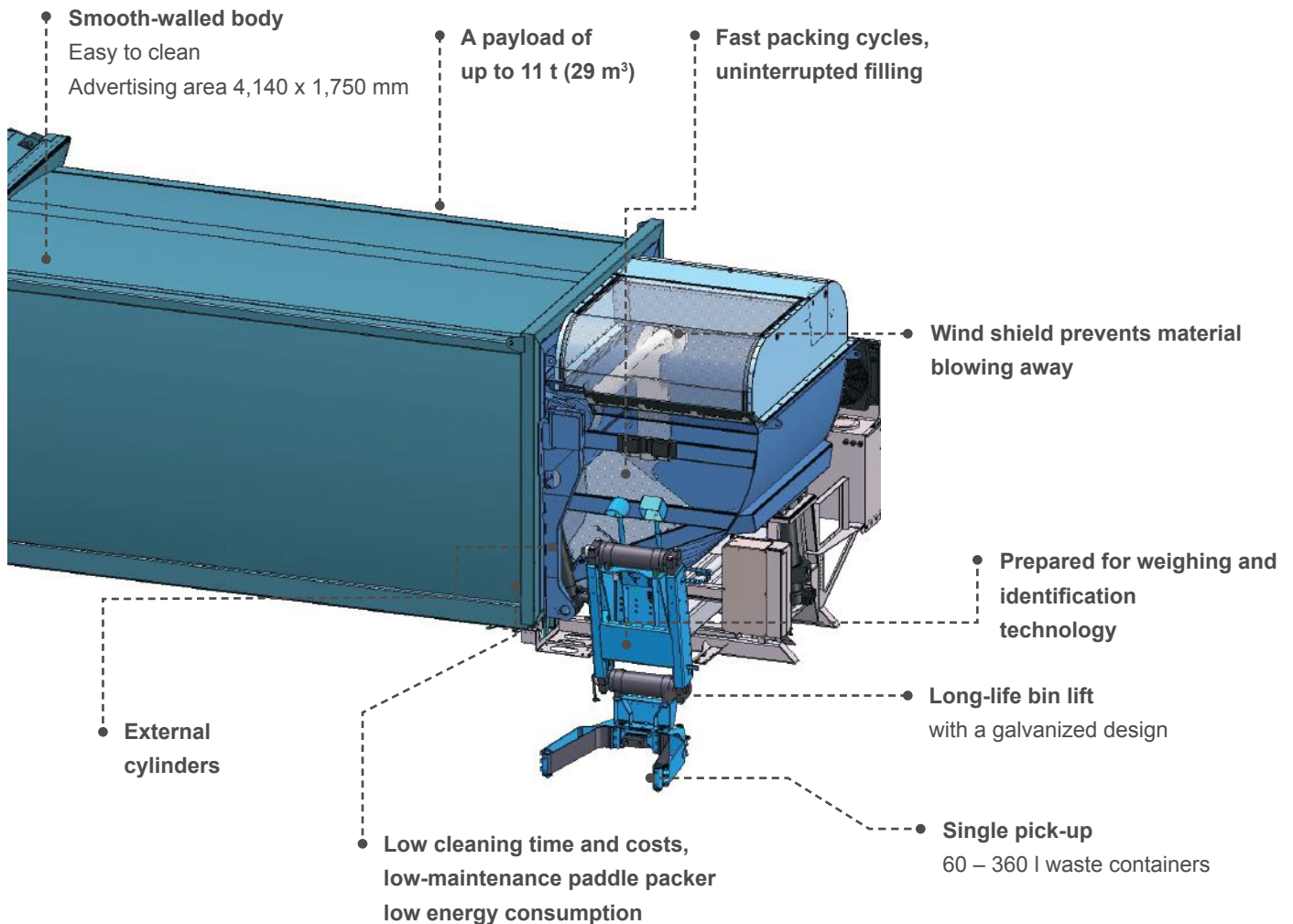

6 GOOD REASONS FOR THE HS SPEEDLINE ACE:

1. FLEXIBILITY



- Single pick-up for 2-wheel waste containers, available as comb, diamond or grabber versions

2. EFFICIENCY



- Single-person operation
- High payloads
- Optimised discharge operation
- Compactor volumes up to 2,0 m³
- Low whole life cost

3. WORK SPEED



- Fast lifting cycles
- Short discharge cycles
- Manoeuvrable thanks to wheel-bases from 3,900 mm

4. SAFETY



- Optional equipment available to monitor side and rear working areas
- Intelligent machine interface with well thought out programming logic
- Camera systems for to 360° viewing
- Additional remote control enables work to be performed outside of the working area

5. COMFORT



- Convenient controls with touch screen (7 or 10 inch)
- Available in left and right-hand-drive
- Sensitive joystick
- Ergonomically shaped armrests
- Quiet operation
- Automated container emptying

6. AVAILABILITY

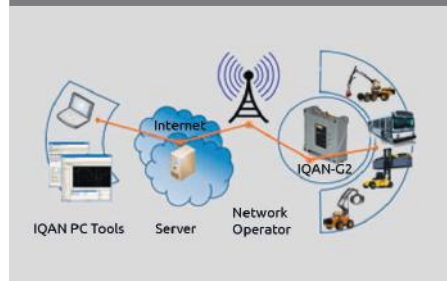

- Requires minimal maintenance
- Remote maintenance via Bluetooth
- Full-service contracts minimise downtime
- Original spare parts available within 24 hours



TERBERG ENVIRONMENTAL, Postbus 20, 3400AE, IJsselstein, The Netherlands

☎ +31 (0) 30 68 68 700 ✉ info@terbergenvironmental.com

www.terbergenvironmental.com