



OmniDEKA+e

Low voltage, high-level electric automatic bin lift

The **OmniDEKA+e**, a low voltage, high level electric bin lift comes with the expected robust build, safe operation and efficiency synonymous with the Terberg brand to provide the market with the best automatic high-level bin lift solution available today. The **OmniDEKA+e** requires only a 24v chassis for operation and has a host of efficiency saving features.

FIVE REASONS TO CHOOSE THE OMNIDEKA+e:

- **OmniDEKA+e** offers great flexibility with mounting heights to suit a variety of applications from 1150mm to 1675mm
- **OmniDEKA+e** provides ultra-strong lifting power for two-wheeled bins of 170kg and up to 700kg for four-wheeled bins
- The modern design of the **OmniDEKA+e** includes large side windows for maximum visibility and increased safety during operation
- Amazingly light, the **OmniDEKA+e** weighs just 680kg (without DIN pick up arms). The centre of gravity sits at 250mm
- Cycle time for two-wheeled EN840-1 containers is six-seven seconds whilst **OmniDEKA+e** will lift, discharge and return a four-wheeled EN840-2 or -3 container in 10-12 seconds

SMART SOLUTIONS

- Short rear overhang projection of just 800mm which increases to 1130mm with the drop down safety arms deployed
- Superbly steep container discharge angle of 46 degrees to reduce the risk of non-emptying bins
- Universal mounting according to EN 1501-1
- 6 per cent more room on the footboards when compared to previous models
- **OmniDEKA+e** dynamic split catcher bar operates automatically as required and moves back to its original position following container discharge
- The user friendly folding safety arms conform to EN1501-1 standard and provides guarding against entry into the functional working space during bin lift operation
- Ground clearance of ± 450 mm
- Kinetic energy is stored during the lifting cycle to provide an energy free chair return under gravity, which in turn reduces noise, saves energy and keeps wear and tear to a minimum
- Single point greasing
- Optional service modem possible
- Designed with weighing in mind, the **OmniDEKA+e** is designed to allow the integration of weighing and identification systems with ease. Consequently, the **OmniDEKA+e** has a smooth operation designed to minimise 'bin bounce' and a vertical initial lift providing a 'window' for ease of data recording
- Noise level only 57 dB(A)

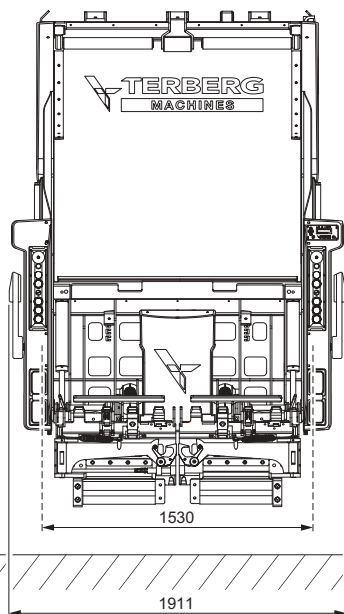

A	B
1200	528
1300	528
1400	528
1500	528
1600	578

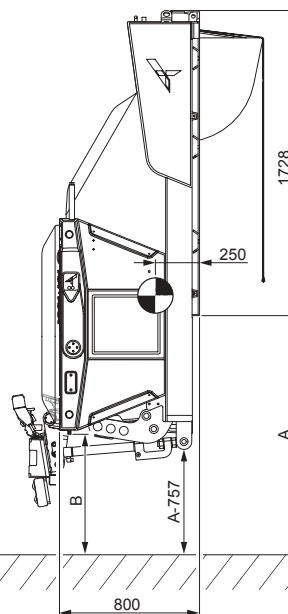

TECHNICAL SPECIFICATION



EN 840-1 MGB



EN 840-2 MGB



EN 840-3 MGB

Chair configuration	Split twin chairs
Single Man Trade (SMT)	Standard
Pick up arms for bins according to EN 840-2/-3 with trunnions	Option
Rear Protective Device (RPD)	Standard
4-wheeled recognition	Standard
Diagnostic display	Standard
Mechanical N1 switch / Sonar N1 switch	Standard
Shaking	Standard
Terberg Weighing and RFID preparation	Option
CleanOpen CANbus output	Option
Packer Cycle Delay Control (PCDC)	Standard
Lifting capacity	170kg (split) / 750kg (linked)
Bin lift weight	ca. 680kg
Power source	Electric
Electrical connections	16-pin / 24 V
Chassis battery requirement	175Ah minimum, ideal 245Ah (for hybrid chassis please consult Terberg)
Chassis alternator requirement	Requires 20A spare capacity. Minimum 75A, 100A recommended
Ingress Protection ratings	Proximity switches/sensors to IP68, "Plug and play" wiring to IP69K
Cycle time	2 wheel secs 6-7 (=dwell 0.5-1.5) / 4 wheel ±10-12 secs
Noise level	< 57 dB(A)
Safety and norm compliance	CE machinery directive certification EN 1501-1 & EN 1505-5
Painted finish	Painted to customer specification