



# OMNIDEL

## AUTOMATIC LOW-LEVEL SPLIT BINLIFT

The **OmniDEL** is an advanced, high quality automatic bin lift made by Terberg, built robustly and safe to operate, resembling the brand name of Terberg. The **OmniDEL** sets itself apart with its improved efficiency and extra safety enhancing features providing the best available low level bin lift.

### REASONS TO THE CHOOSE THE OMNIDEL:

- The **OmniDEL** only weighs 595 kg.
- The **OmniDEL** is equipped with 4-wheel recognition, which means that it automatically switches when emptying 4-wheeled bins.
- The one-of-a-kind geometry of the OmniDEL guarantees that the operator does not need to take a step backwards during collection cycle, and it has a remarkable discharge angle of 50°.
- A single point greasing system is integrated in the standard equipment which contributes to shorter maintenance intervals.

### SMART SOLUTIONS

- The **OmniDEL** has a unique ultrasonic anti spilling system. This system detects any material which might still be left in the bin, automatically shakes the load one time so that all remaining material is collected, and places the container back on the ground.
- The Rear Protective Device comes as standard and complies to safety norm EN 1501.5. This is active during automatic loading of the 2-wheeled containers.
- Shock and water resistant IP69K automotive parts, low-maintenance bearings, contactless sensors and switch elements offer perfect protection against the often heavy daily working conditions.
- The **OmniDEL** is designed in such a way that it can easily be provided with a dynamic weighing system and that it is prepared for the various identification systems.
- The **OmniDEL** is designed in such a way that it lifts the container with low speed at first, and speeds up afterwards. Ergonomically and in terms of working conditions, this is ideal because it minimises duty on wrists and shoulders.
- All electrical connections are 'plug and play', meaning that replacement of defect parts happens quickly and easily. A cleverly designed diagnosis system helps you with tracking down malfunctions and guarantees less standstill during maintenance.

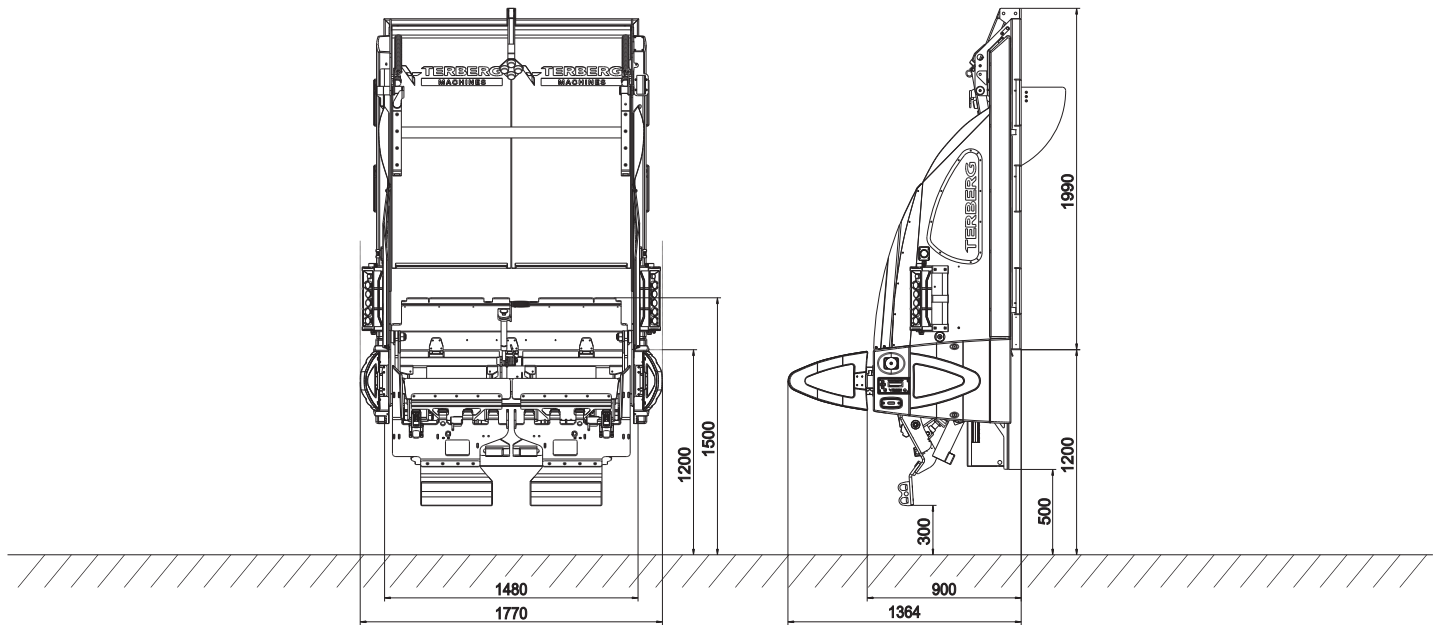

## TECHNICAL SPECIFICATIONS



<b>Chair configuration</b>	Split twin chair	
<b>Single Man Trade (SMT)</b>	Standard	
<b>Rear protection device (RPD)</b>	Standard	
<b>4-wheel container recognition</b>	Standard	
<b>Diagnostic display</b>	Standard	
<b>Sonar Switch / Mechanical Switch</b>	Standard	Option
<b>Sonar Sensor Anti-Spillage System</b>	Standard	
<b>Terberg Weighing &amp; RFID preparation</b>	Option	
<b>CleAN Open CANbus output</b>	Option	
<b>Packer Cycle Delay Control (PCDC)</b>	Option	
<b>Lifting capacity</b>	160kg (split) / 500kg (linked)	
<b>Weight</b>	595 kg	
<b>Power source</b>	Hydraulic	
<b>Electrical connections</b>	16-polige stekker / 24v	
<b>Hydraulic connections</b>	quick release couplings (DIN 2353, NW13, NW20)	
<b>Hydraulic requirement</b>	ideal 40 ltr/min., maximum 60 ltr/min., 180 bar	
<b>Cycle time</b>	2-wheel containers 6 - 7 sec. / 4-wiel 10-12 sec.	
<b>Noise level</b>	< 65 dB(A)	
<b>Safety</b>	CE machinery directive certification EN 1501-1 & EN 1505-5	